

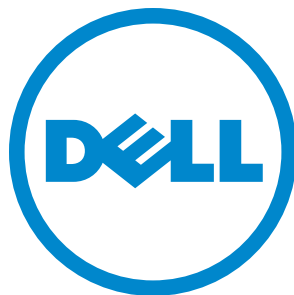

# Installing and Maintaining the C7004/C150 System



## Notes, Cautions, and Warnings

 **NOTE:** A NOTE indicates important information that helps you make better use of your computer.

 **CAUTION:** A CAUTION indicates potential damage to hardware or loss of data if instructions are not followed.

 **WARNING:** A WARNING indicates a potential for property damage, personal injury, or death.

---

**Information in this publication is subject to change without notice.**

© 2014 Dell. All rights reserved.

Reproduction of these materials in any manner whatsoever without the written permission of Dell Inc. is strictly forbidden.

© 2014 Dell Inc.

Copyright © 2014 Dell Inc. All rights reserved. This product is protected by U.S. and international copyright and intellectual property laws. Dell and the Dell logo are trademarks of Dell Inc. in the United States and/or other jurisdictions. All other marks and names mentioned herein may be trademarks of their respective companies.

April 2014

# Contents

- 1 About this Guide
  - Information Symbols and Warnings . . . . . 7
  - Related Documents. . . . . 8
  
- 2 Overview
  - C7004/C150 System Installation Process Overview. . . . . 9
  
- 3 Preparing the Site
  - Site Selection Criteria . . . . . 11
  - Preparing the Equipment Rack . . . . . 11
  - Power Requirements. . . . . 12
  - Shipping and Storing Components . . . . . 12
  
- 4 Installing the C7004/C150 Chassis
  - Safety Considerations . . . . . 15
  - Installing the Chassis into an Equipment Rack. . . . . 16
  
- 5 RPMs and Line Cards
  - Route Processor Modules. . . . . 19
    - RPM Label and LEDs . . . . . 19
  - Line Cards. . . . . 20
  - Blank Panels . . . . . 20
  - Installing RPMs and Line Cards . . . . . 21
  - Removing RPMs and Line Cards . . . . . 24
  
- 6 Management Cable Pinout
  - Connecting the Console Port . . . . . 25
  - Cable and Adapter Pin Assignments . . . . . 25
    - Accessing the Console with a DB-9 Adapter . . . . . 26
    - Accessing the Console with a DB-25 Adapter . . . . . 26
  
- 7 AC Power Supply Units
  - Power Over Ethernet. . . . . 31
  - . . . . . 32
  
- 7 Installing Power Supply Units

Removing AC Power Supply Units . . . . .	33
Power Cord Requirements . . . . .	34
<b>8 Installing DC Power Entry Modules</b>	
Recommended Normal Operating Conditions . . . . .	35
Redundancy . . . . .	35
Cable and Connector Requirements . . . . .	35
Installing a DC PEM . . . . .	36
Status LED . . . . .	39
Removing a DC PEM . . . . .	39
<b>9 Powering Up</b>	
<b>10 Fan Tray</b>	
Installing the Fan Tray . . . . .	46
Removing the Fan Tray . . . . .	46
Fan Speed . . . . .	46
<b>11 Removing and Replacing Components</b>	
Removing and Replacing the Fan Tray . . . . .	47
Removing and Replacing Power Supply Units . . . . .	48
Removing and Replacing a Line Card . . . . .	49
Removing and Replacing an RPM . . . . .	49
<b>12 System Boot</b>	
Booting from the BOOT_USER Prompt . . . . .	51
<b>13 The Compact Flash Card</b>	
Inserting the Compact Flash Card . . . . .	55
Removing the Compact Flash Card . . . . .	55
Formatting the Compact Flash Card . . . . .	56
<b>Alarms</b>	
AC Power Supplies and Alarms . . . . .	58
<b>B System Specifications</b>	
Physical Design . . . . .	59
Component Power Requirements . . . . .	62
Agency Compliance . . . . .	63
Safety Standards and Compliance Agency Certifications . . . . .	65
Electromagnetic Compatibility (EMC) . . . . .	65

Product Recycling and Disposal .....	65
<b>Contacting Technical Support</b>	
The iSupport Website .....	67
Accessing iSupport Services .....	67
Contacting the Technical Assistance Center .....	67
Locating Serial Numbers .....	68
Requesting a Hardware Replacement .....	68



## About this Guide

This guide provides site preparation recommendations and instructions for installing the Dell Networking C7004/C150 chassis, fan tray, power supply units (PSUs), route processor modules (RPMs), and line cards.



The C-series system is packaged with all of the necessary components, including slot blanks for RPMs, power supplies, and line cards.

## Information Symbols and Warnings

The following graphic symbols are used in this document to bring attention to hazards that exist when handling the C7004/C150 and its components. Please read these alerts and heed their warnings and cautions.

[Table 1-1](#) describes symbols contained in this guide.

**Table 1-1. Information Symbols**

Symbol	Warning	Description
	Note	This symbol informs you of important operational information.
	Caution	This symbol informs you that improper handling and installation could result in equipment damage or loss of data.
	Warning	This symbol signals information about hardware handling that could result in injury.

 **WARNING:** The installation of this equipment shall be performed by trained and qualified personnel only. Read this guide before installing and powering up this equipment. This equipment contains two AC power cords. Disconnect both power cords before servicing.







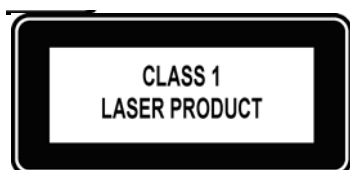







 **WARNING:** Class 1 laser product.

 **ATTENTION:** Produit laser de classe 1

 **WARNING:** Laserprodukt der Klasse 1



 **WARNING:** This equipment contains optical transceivers, which comply with the limits of Class 1 laser radiation. Visible and invisible laser radiation may be emitted from the aperture of the optical transceiver ports when no cable is connected. Avoid exposure to laser radiation and do not stare into open apertures.

-  **WARNING:** Building Supply Notice for AC Power Supply Use: This product relies on the building's installation for short-circuit (overcurrent) protection. Ensure that a fuse or circuit breaker no larger than 120 VAC, 15A U.S. (240 VAC, 10A international) is used on the phase conductors (all current-carrying conductors).
-  **ATTENTION:** Pour ce qui est de la protection contre les courts-circuits (surtension), ce produit dépend de l'installation électrique du local. Vérifier qu'un fusible ou qu'un disjoncteur de 120 V alt., 15 A U.S. maximum (240 V alt., 10 A international) est utilisé sur les conducteurs de phase (conducteurs de charge).
-  **WARNUNG:** Dieses Produkt ist darauf angewiesen, daß im Gebäude ein Kurzschluß- bzw. Überstromschutz installiert ist. Stellen Sie sicher, daß eine Sicherung oder ein Unterbrecher von nicht mehr als 240 V Wechselstrom, 10 A (bzw. in den USA 120 V Wechselstrom, 15 A) an den Phasenleitern (allen stromführenden Leitern) verwendet wird.
-  **WARNING:** Building Supply Notice for DC Power Supply Use: An external disconnect must be provided and be easily accessible. Dell Networking recommends the use of a 60A circuit breaker.
-  **ATTENTION:** Un interrupteur externe doit être fournis et doit être facilement accessible. Dell Networking recommande l'utilisation d'un disjoncteur de 60Ampères.
-  **WARNUNG:** Eine leicht zugängliche Tren Dell Networking nvorrichtung muss in der Verdrahtung eingebaut sein. Dell Networking empfiehlt einen 60A Sicherungsautomaten zu benutzen.
-  **CAUTION:** Wear grounding wrist straps when handling this equipment to avoid ESD damage.
-  **CAUTION:** Earthing (AKA grounding) connection essential before connecting supply. Always make the ground connection first and disconnect it last.
-  **CAUTION:** Disposal of this equipment should be handled according to all national laws and regulations. See [Product Recycling and Disposal](#) on page 65.
-  **CAUTION:** This unit has more than one power supply connection; all connections must be removed to remove all power from the unit.
-  **ATTENTION:** Cette unité est équipée de plusieurs raccordements d'alimentation. Pour supprimer tout courant électrique de l'unité, tous les cordons d'alimentation doivent être débranchés.
-  **WARNUNG:** Diese Einheit verfügt über mehr als einen Stromanschluß; um Strom gänzlich von der Einheit fernzuhalten, müssen alle Stromzufuhren abgetrennt sein.
-  **CAUTION:** Lithium Battery Notice: Danger of explosion if battery is replaced with incorrect type. Replace only with the same type recommended by the manufacturer. Dispose of used batteries according to the manufacturer's instructions.
-  **ACHTUNG:** Explosionsgefahr wenn die Battery in umgekehrter Polarität eingesetzt wird. Nur miteinem gleichen oder ähnlichen, vom Hersteller empfohlenen Typ, ersetzen. Verbrauchte Batterien müssen per den Instructionen des Herstellers verwertet werden.
-  **ATTENTION:** Il y a danger d'explosion s'il a remplacement incorrect de la batterie. Remplacer uniquement avec une batterie du meme type ou d'un type equivalent recommande par le constructeur. Mettre au rebut les batteries usages conformement aux instructions du fabricant.

 **NOTE:** Other cautionary statements appear in context elsewhere in this book.

## Related Documents

For information about the Dell Networking OS, refer to the following documents:

- Dell Networking OS Command Reference for C-Series
- *Dell Networking OS Configuration Guide for C-Series*



## Overview

The C7004/C150 is a high performance switch/router. This 6-slot system contains two slots for Route Processor Modules (RPMs) and four slots for line cards ([Figure 2-1](#)).

**Figure 2-1. C7004/C150 Chassis (Front View)**

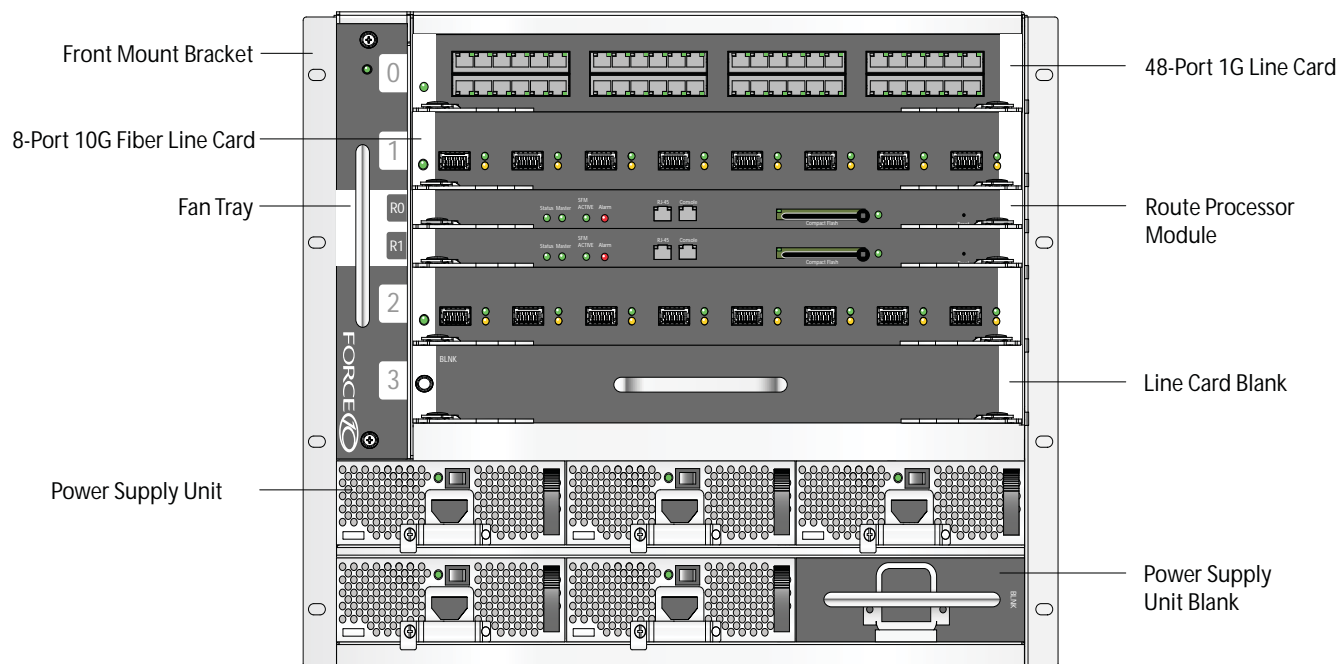

**Table 2-1. C7004/C150 Component Requirements**

Component	Minimum	Maximum	Field-Replaceable
Backplane (factory installed)	1	1	No
Fan tray	1	1	Yes
RPM	1	2	Yes
Line card	1	4	Yes
AC Power Supply	1	6	Yes

## C7004/C150 System Installation Process Overview

The Dell Networking recommended installation process is summarized below.

Step	Task	Relevant Section in the Manual
1	Prepare the site.	<a href="#">Site Selection Criteria on page 11</a>
2	Unpack the chassis and components.	<a href="#">Shipping and Storing Components on page 12</a>

<b>Step</b>	<b>Task</b>	<b>Relevant Section in the Manual</b>
3	Install the chassis in a rack.	<a href="#">Installing the Chassis into an Equipment Rack on page 16</a>
4	Install the fan tray.	<a href="#">Fan Tray on page 45</a>
5	Install the RPMs and line cards.	<a href="#">RPMs and Line Cards on page 19</a>
6	Connect console and management cables.	<a href="#">Management Cable Pinout on page 25</a>
7	Install the power supplies.	<a href="#">AC Power Supply Units on page 29</a>
8	Switch on all of the power supplies.	<a href="#">Powering Up on page 41</a>

# Preparing the Site

## Site Selection Criteria

Before beginning the installation process, make sure that the area where you intend to install your C7004/C150 meets the following safety requirements:

- It is in a restricted access area.
- It is in a dry, clean, well-ventilated, temperature-controlled room, that is away from heat sources such as hot air vents or direct sunlight.
- It is away from sources of severe electromagnetic noise.
- It is near an adequate power source.
  - The AC power supply cord is used as the main disconnect device; ensure that the socket outlet is located/installed near the equipment and is easily accessible.
  - Connect the C7004/C150 to the appropriate branch circuit protection, as defined by local electrical codes.
- It is positioned in a rack with adequate space in the front, rear, and sides of the unit for proper ventilation, access to cables, and maintenance access.
  - Allow *at least* six inches (16 cm) of clearance around the side intake and exhaust vents.
  - Allow *at least* 12 inches (30.5 cm) between two C7004/C150s or a C7004/C150 and another side airflow chassis.
  - Allow *at least* 18 inches in the front and rear of the rack.

 **NOTE:** The C-Series does not have an air filter, so take special care in making sure that the installation site and the chassis itself are cleaned regularly.

## Preparing the Equipment Rack

When you prepare your equipment rack:

- Make sure that the rack is bolted to the floor and braced to a wall or ceiling.
- Make sure that the rack is permanently grounded to earth ground. The equipment rack must be grounded to the same ground point used by the power service in your area.
- The AC power cord is the primary ground.

When you install the chassis, use a level to ensure that the chassis is installed level.

## Power Requirements

There are two types of power supplies: Power Supply 1200W-AC and Power Supply 1600W-AC. The minimum and the redundant power supplies required to operate is listed in the table below. Dell Networking recommends the redundancy configuration.

	Voltage	Minimum PSUs	Minimum with Redundant PSUs
Power Supply 1200W-AC/Power Supply 1600W-AC	100-120	1	2
Power Supply 1200W-AC	200-240	1	2
Power Supply 1600W-AC	200-240	1	2

The C7004/C150 needs at least one power supply to operate. However, Dell Networking recommends a one-plus-one redundancy configuration. That is, use a minimum of two AC or DC power supplies; one is for redundancy.

The C7004/C150 power requirements are given below:

**Table 3-1. System Specifications**

Parameter	Specifications
Nominal Input Voltage	100-240 V 50/60 Hz
Maximum AC Power Supply Input Current (Based on 1200 W output for 100/120 V and 1600 W 200/240 V lines)	14 A @ 100 V per AC Power Supply 11 A @ 120 V per AC Power Supply 9 A @ 200 V per AC Power Supply 7 A @ 240 V per AC Power Supply
Maximum System Power Input	6,897 KVA @ 100/120 V 7,315 KVA @ 200/240 V
Maximum Thermal Output at 100/120V	5,618 BTU/hour
Maximum Thermal Output at 200/240V	5,304 BTU/hour

## Shipping and Storing Components

If you do not install your C7004/C150 system and components immediately, Dell Networking recommends you properly store components (including all extra field-replaceable parts) until you are ready to install them.

Follow these indoor storage guidelines:

- Storage temperature should remain constant ranging from -40°F to 158°F (-40°C to 70°C).
- Non-condensing relative humidity should be maintained with 5 to 95%.
- Store on a dry floor, away from direct sunlight, heat, and air conditioning ducts.
- Store in a dust-free environment.





Save the protective packaging in which your line cards, RPMs, power supplies, and fan tray arrived. The packaging can be used in case you experience trouble with a component and must return it to Dell Networking. Place the components in their original protective shipping packaging and original shipping position.

 **NOTE:** Do not transport the chassis with the components (line cards, power supplies, and RPMs) installed. Place the components in their original protective shipping packaging and original shipping position. Shipping components installed in the chassis or without their protective packaging, might damage the components or the backplane.



# Installing the C7004/C150 Chassis

## Safety Considerations

-  **NOTE:** Use an equipment lift or pallet jack when lifting or moving the chassis. Install the chassis into the rack before inserting chassis components. Lift the C7004/C150 chassis *only* from the bottom. Lifting by the chassis shelves or power supply openings might damage the chassis.
-  **WARNING:** To prevent bodily injury when mounting or servicing this unit in a rack, you must take special precautions to ensure that the system remains stable. The following guidelines are provided to ensure your safety:
- This unit should be mounted at the bottom of the rack if it is the only unit in the rack.
  - When mounting this unit in a partially filled rack, load the rack from the bottom to the top with the heaviest component at the bottom of the rack.
  - If the rack is provided with stabilizing devices, install the stabilizers before mounting or servicing the unit in the rack.
-  **ATTENTION:** Pour éviter toute blessure corporelle pendant les opérations de montage ou de réparation de cette unité en casier, il convient de prendre des précautions spéciales afin de maintenir la stabilité du système. Les directives ci-dessous sont destinées à assurer la protection du personnel:
- Si cette unité constitue la seule unité montée en casier, elle doit être placée dans le bas.
  - Si cette unité est montée dans un casier partiellement rempli, charger le casier de bas en haut en plaçant l'élément le plus lourd dans le bas.
  - Si le casier est équipé de dispositifs stabilisateurs, installer les stabilisateurs avant de monter ou de réparer l'unité en casier.
-  **WARNUNG:** Zur Vermeidung von Körperverletzung beim Anbringen oder Warten dieser Einheit in einem Gestell müssen Sie besondere Vorkehrungen treffen, um sicherzustellen, daß das System stabil bleibt. Die folgenden Richtlinien sollen zur Gewährleistung Ihrer Sicherheit dienen:
- Wenn diese Einheit die einzige im Gestell ist, sollte sie unten im Gestell angebracht werden.
  - Bei Anbringung dieser Einheit in einem zum Teil gefüllten Gestell ist das Gestell von unten nach oben zu laden, wobei das schwerste Bauteil unten im Gestell anzubringen ist.
  - Wird das Gestell mit Stabilisierungszubehör geliefert, sind zuerst die Stabilisatoren zu installieren, bevor Sie die Einheit im Gestell anbringen oder sie warten.

# Installing the Chassis into an Equipment Rack

Follow these steps to install the chassis into a 19-inch equipment rack:

Step	Task
1	<p>Dell Networking recommends that you install a equipment rack bar. This bar enables you to easily position the chassis into the rack and stabilizes the chassis.</p> <ul style="list-style-type: none"><li>• Orient the equipment rack bar at the desired location in the rack, with the arrows pointing up and the smooth side facing outward.</li></ul>

**Figure 4-1. Installing the Equipment Rack Bar**

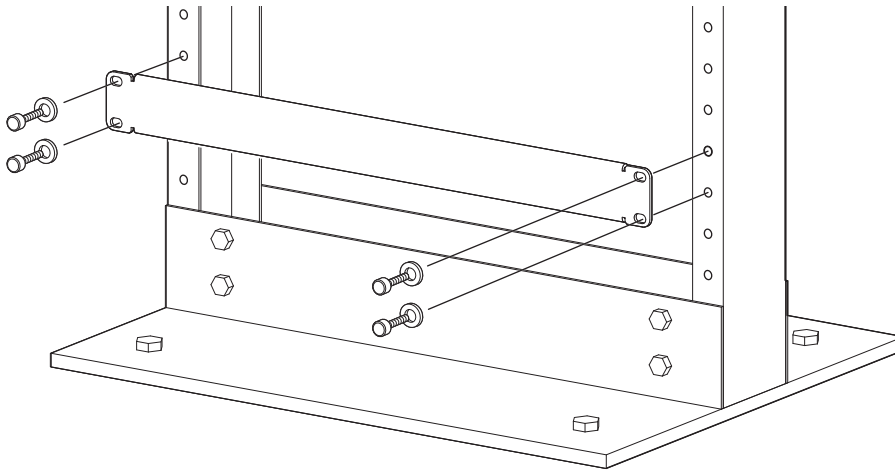

- 2 Attach the bar to the rack ([Figure 4-1](#)) using the mounting screws provided with your rack.
- 3 Use an equipment lift to align the chassis rack-mount holes with the equipment rack holes, and situate the chassis on top of the equipment rack bar.



---

Step	Task
4	Insert screws (provided with your rack) through the chassis rack-mounting bracket and into the equipment rack, and tighten them ( <a href="#">Figure 4-2</a> ).

---

**Figure 4-2. Rack Mounting the Chassis**

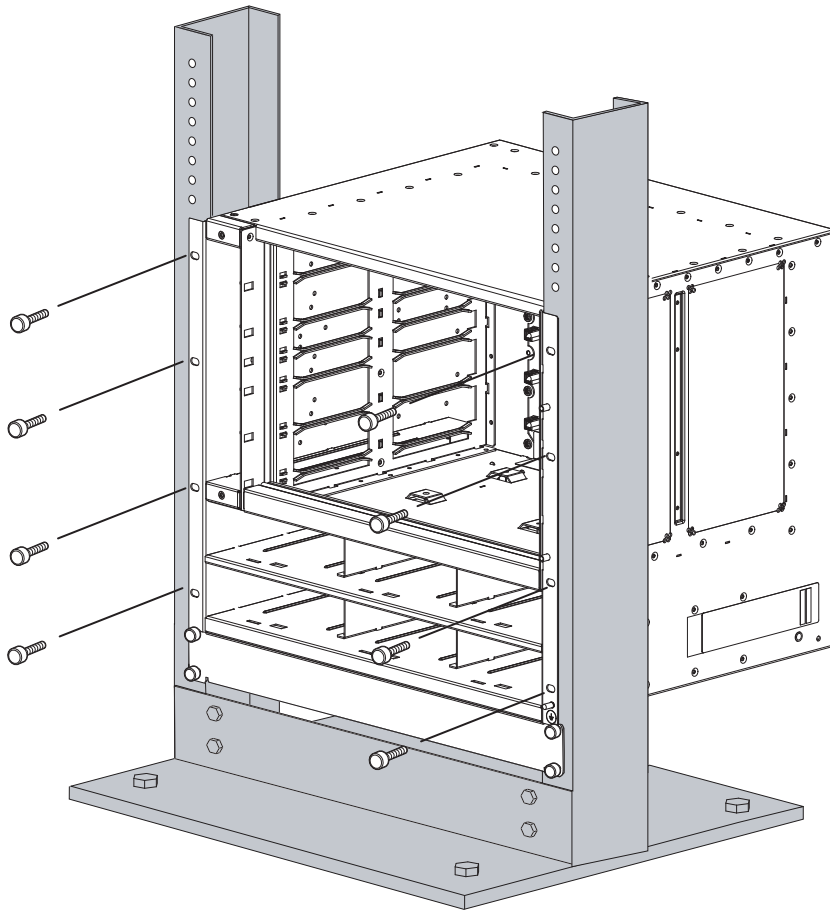



## RPMs and Line Cards

The C7004/C150 system accommodates four line cards and two Route Processor Modules (RPMs).

### Route Processor Modules

The C7004/C150 system requires the installation of at least one RPM; two are recommended.

- One RPM provides each line card with 48 Gigabits of backplane bandwidth.
- Two RPMs provides each line card with 96 Gigabits of backplane bandwidth.

RPMs can be installed in either the R0 or R1 slot as shown in [Figure 2-1 on page 9](#). Do not force RPMs into card slots. RPMs are keyed differently than line cards to prevent improper installation.

The RPM must be running Dell Networking OS version 7.6.1.0 or later.

- 🔪 **NOTE:** RPMs are hot-swappable. High Availability is supported.
- 🔪 **NOTE:** If your system contains two RPMs, both RPMs must have the same software image.
- 🔪 **NOTE:** RPMs are interchangeable between the C7008/C300 and the C7004/C150 only if they are running Dell Networking OS version 7.6.1.0 or later.

### RPM Label and LEDs

- 🔪 **NOTE:** RPMs are hot-swappable. High Availability is supported.

[Table 5-1](#) describes the RPM LED states and the RPM front panel.

**Table 5-1. RPM Front Panel and LED Descriptions**

Section	Label	Description
Management	Console Port	Use this RJ-45 jack for the initial system boot, as well as system configuration and monitoring. A modem connection is not available.
	10/100/1000 Ethernet	Use this non-routable Ethernet port to download images and manage the system. FTP and Telnet operations are supported. This port is an RJ-45. <b>Port LEDs:</b> Link/Activity: Blinking Amber: 100M speed Solid Amber: 1G speed Off: 10M speed Speed: Blinking Green: Link detected/ Activity Solid Green: Link detected/ No Activity Off: No Link/ Card Offline

**Table 5-1. RPM Front Panel and LED Descriptions (continued)**

Section	Label	Description
Alarm LED		Red: Major Alarm—a critical condition exists (such as a severe over-temperature condition). See <a href="#">Appendix , Alarms, on page 57</a> for more information. Flashing red: Minor Alarm—a serious condition exists (such as a single fan failure or a line card failure). See <a href="#">Appendix , Alarms, on page 57</a> for more information. Unlit: No alarm conditions.
Flash	Slot	Use the compact flash card (external compact flash memory card) slot to store and retrieve boot and system images.
	In Use LED	Green: The flash memory card is in the process of a read or write process. Do not remove the flash card when the In Use LED is lit. Unlit: Not in use
	Master LED	Indicates that this RPM is the Primary RPM Green: Primary Unlit: Secondary/ fatal error/ booting
	Reset Button	Use this recessed reset switch to reset the RPM by inserting a small object, such as a pen tip, to depress the button.
	SFM Active	Green: Switch Fabric is active Unlit: Switch Fabric is inactive
	Status LED	Green: Operational Red: Card problem state Flashing green: Booting/ diagnostics Unlit: In standby mode, or power is off

## Line Cards

Line cards are hot-swappable. Any line card can be inserted into any line card slot. Line card slots are numbered 0 to 3; the number label is on the fan tray. The LC-CB-GE-48P and LC-CB-10GE-8P line cards can only be installed in a chassis running Dell Networking OS version 7.6.1.0 or later.

 **NOTE:** The LC-CB-GE-48P and LC-CB-10GE-8P line cards are interchangeable between the C7008/C300 and C7004/C150 only if the chassis is running Dell Networking OS version 7.6.1.0 or later.

Line card LEDs are described in the documentation specific to each line card. Refer to the installation documentation that came with the card for to understand LED appearance and meaning.

## Blank Panels

Blanks are required in empty slots to control airflow for adequate system cooling, personal safety, and EMI containment during operation.

The blank panels do not have board components or connector pins. Align the blank with the guides and gently slide toward the backplane ([Figure 5-5](#) and [Figure 5-6](#)).

 **NOTE:** All chassis slots must be installed with operational modules or blanks. Always replace cards and blank panels immediately.

# Installing RPMs and Line Cards

**⚠ WARNING:** Always wear an ESD-preventive wrist or foot-heel ground strap when handling RPMs or line cards. Place RPMs and line cards on an antistatic surface when they are not installed. Electrostatic discharge (ESD) damage can occur when components are mishandled.

**⚠ CAUTION:** Unlock the levers before inserting the line card into the chassis. Fully engage the locking mechanism after the card has been inserted; not doing so might damage the card below it when that lower card is inserted.

**🔧 NOTE:** The fan tray face panel has slot number markings for the RPMs and line cards. Insert the fan tray before the line cards to simplify RPM and line card installation.

To install a card:

Step	Task
1	Extend the left and right card levers by first pressing gently down on the thumb tabs (Figure 5-1) in the ejector levers and then pulling the ejector levers simultaneously until they are in the open position, as shown in Figure 5-2.

**Figure 5-1. Depressing the Thumb Tabs**



**Figure 5-2. Extending the Levers**



- 2 Hold the card assembly by the metal carrier edges. Avoid touching the printed circuit board and connector pins.
- 3 Align the card with the guide, and gently slide it into any line card slot until the card is about halfway into the slot.  
**🔧 NOTE:** Use the markings on the fan tray to determine which slots are for the RPMs and which are for the line cards.
- 4 Continue sliding the card until you feel the connectors engage with the chassis backplane.

---

Step	Task
5	Rotate the levers toward the card to seat the backplane connectors and line card in place. Push on the knurled section of the levers until the thumb tabs pop up and lock the unit in place, as shown in <a href="#">Figure 5-3</a> and <a href="#">Figure 5-4</a> .

---

**CAUTION:** Installing a card without fully engaging the locking mechanism might damage the EMI seal on the card below it when that card is inserted.

**Figure 5-3. Closing the Levers**



**Figure 5-4. Pressing the Knurled Section of the Lever**



- 6 Install a blank panel in all slots that do not have a card, and secure it with the screws provided.

**NOTE:** The blank panels for RPMs and line cards are different sizes (RPM blanks are smaller); be sure that blank panels are installed in the correct slots.

---

**Figure 5-5. Installing a Line Card**

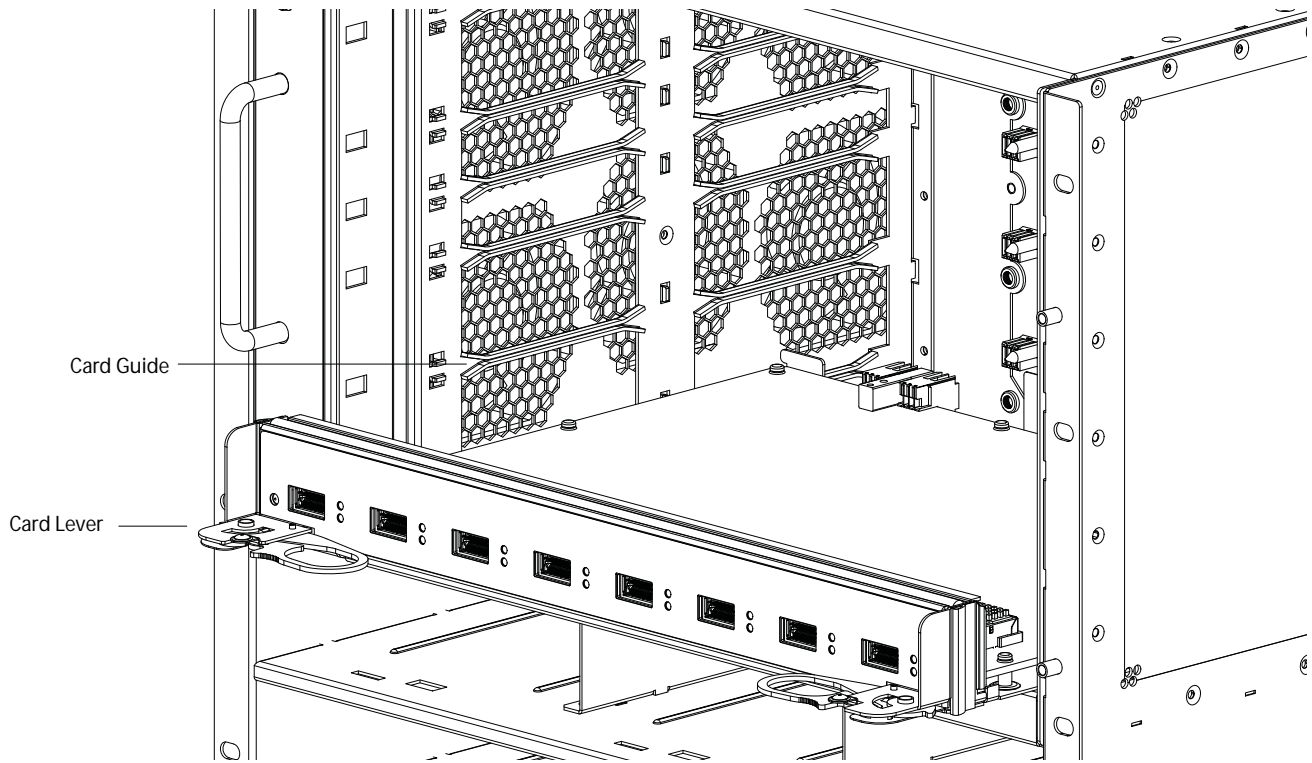

**Figure 5-6. Installing an RPM**

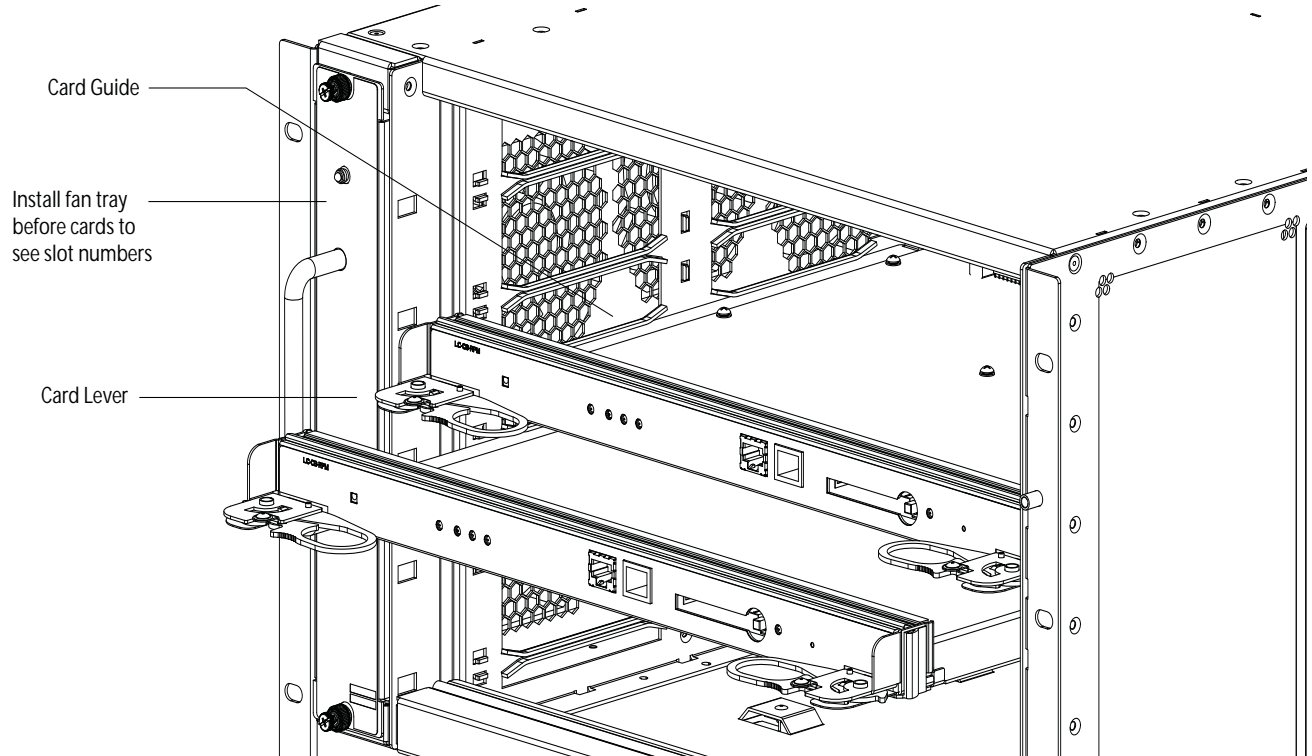

## Removing RPMs and Line Cards

**⚠ WARNING:** After removing an RPM, place a panel blank in the empty slot before powering up the chassis. Blanks are required to control airflow and electromagnetic interference.

**🔧 NOTE:** The C7004/C150 requires at least one RPM to operate. The system enters a software-defined power-down state if you remove the only RPM.

To remove a C7004/C150 RPM or line card:

Step	Task
1	Unplug any network interface cables connected to the card.
2	Extend the left and right card levers by first pressing gently down on the thumb tabs (see <a href="#">Figure 5-7</a> ) in the ejector levers and then pulling the ejector levers simultaneously until they are in the open position. See <a href="#">Figure 5-8</a> .

**Figure 5-7. Depressing the Thumb Tabs**

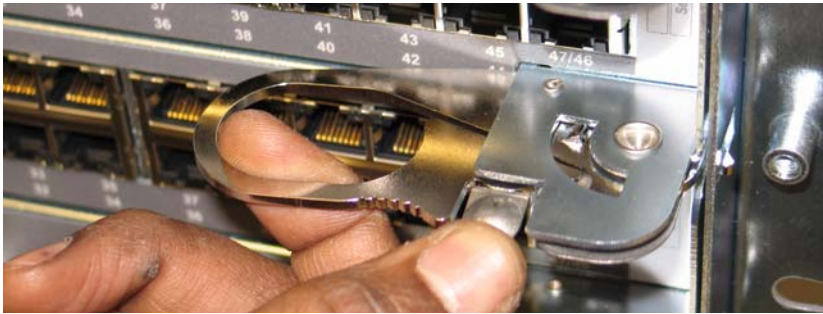

**Figure 5-8. Extending the Levers**



- 3 Pull the card by the card levers until it is out of the slot. Avoid touching the printed circuit board and connector pins.
- 4 Install a blank panel in all slots that do not have a card, and secure it with the screws provided.
 

**🔧 NOTE:** The blank panels for RPMs and line cards are different sizes (RPM blanks are smaller); be sure that blank panels are installed in the correct slots.
- 5 If you are replacing the card, follow the instructions in [Installing RPMs and Line Cards on page 21](#).



# Management Cable Pinout

## Connecting the Console Port

The console port is an asynchronous serial port. If you connect a device to these ports, it must be capable of asynchronous transmission. Your terminal or terminal emulation mode must be set to VT100 with the following settings:

- 9600 baud rate (To avoid autobaud input, the default is set to a 9600 BPS.)
- No parity
- 8 data bits
- 1 stop bit
- Window Terminal Emulator option set to **NO**
- 24 lines X 80 characters
- No flow control

## Cable and Adapter Pin Assignments

Use the console port on the RPM of the C7004/C150 to connect to a terminal port, PC serial port, or a terminal server to configure and monitor your system. An RJ-45 Ethernet cable is required to connect to the Ethernet port.

The console port is an RJ-45, the pinouts of which are shown in [Figure 6-1](#).

**Figure 6-1. Pinouts for an RJ-45 Connector End of Adaptors**

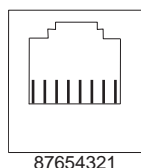

[Table 6-1](#) displays the RJ-45 console port pin assignments.

**Table 6-1. Console Port (RJ-45) Pin Assignments**

Pin	Signal	Input/Output
1	NC (unused)	-
2	DTR	Output
3	TxD	Output
4	GND	-

**Table 6-1. Console Port (RJ-45) Pin Assignments**

Pin	Signal	Input/Output
5	GND	-
6	RxD	Input
7	DSR	Input
8	NC (unused)	-

### Accessing the Console with a DB-9 Adapter

You can connect to the console using an RJ-45 to RJ-45 rollover cable and an RJ-45 to DB-9 female DTE adapter (labeled “TERMINAL”) to a terminal server (for example, PC). [Table 6-2](#) lists the pin assignments.

**Table 6-2. Pin Assignments Between the C7004/C150 Console and a DTE Terminal Server**

C7004/C150 System Console Port	RJ-45 to RJ-45 Rollover Cable		RJ-45 to DB-9 Adapter	Terminal Server Device
Signal	RJ-45 Pinout	RJ-45 Pinout	DB-9 Pin	Signal
RTS	1	8	8	CTS
DTR	2	7	6	DSR
TxD	3	6	2	RxD
GND	4	5	5	GND
GND	5	4	5	GND
RxD	6	3	3	TxD
DSR	7	2	4	DTR
CTS	8	1	7	RTS

### Accessing the Console with a DB-25 Adapter

You can connect to the console port using an RJ-45 to RJ-45 rollover cable and an RJ-45 to a DB-25 female DTE adapter. [Table 6-3](#) lists the pin assignments.

**Table 6-3. Pin Assignments Between C7004/C150 Console and DB-25 Adapter**

C7004/C150 System Console Port	RJ-45 to RJ-45 Rollover Cable		RJ-45 to DB-25 Modem Adapter	Terminal Server Device
Signal	RJ-45 Pinout	RJ-45 Pinout	DB-25 Pinout	Signal
RTS	1	8	5	CTS
DTR	2	7	6	DSR
TxD	3	6	3	RxD
GND	4	5	7	GND
GND	5	4	7	GND
RxD	6	3	2	TxD
DSR	7	2	20	DTR

**Table 6-3. Pin Assignments Between C7004/C150 Console and DB-25 Adapter (*continued*)**

<b>C7004/C150 System Console Port</b>	<b>RJ-45 to RJ-45 Rollover Cable</b>		<b>RJ-45 to DB-25 Modem Adapter</b>	<b>Terminal Server Device</b>
<b>Signal</b>	<b>RJ-45 Pinout</b>	<b>RJ-45 Pinout</b>	<b>DB-25 Pinout</b>	<b>Signal</b>
CTS	8	1	—	RTS



## AC Power Supply Units

The C7004/C150 has six power supply slots at the bottom front of the chassis ([Figure 7-1](#)).

**CAUTION:** Do not install the Power Supply 1200W-AC and Power Supply 1600W-AC in the same chassis. The line cards will power down and data may be lost.

- The minimum and the redundant power supplies required to operate is listed in the table below. Dell Networking recommends the redundancy configuration. Any surplus power that is available from the system PSU is allocated to the PoE/PoE+ ports. Power from the redundant PSU is not available for PoE/PoE+. Any power from additional PSUs, excluding the redundant PSU, is allocated for PoE/PoE+. See [Power Over Ethernet](#).

	Voltage	Minimum PSUs	Minimum with Redundant PSUs
Power Supply 1200W-AC/Power Supply 1600W-AC	100-120	1	2
Power Supply 1200W-AC	200-240	1	2
Power Supply 1600W-AC	200-240	1	2

- To protect against high-voltage shock, install a power supply blank on all unused power supply slots.
- Connect the C7004/C150 AC power supply to the appropriate branch circuit protection as defined by local electrical codes.
- Verify that the remote power source complies with the system input power specifications in the section [System Power Specifications on page 62](#).

**WARNING:** The C7004/C150 does not have a main disconnect device installed. It is the responsibility of the installer to provide a suitable disconnecting device in the building installation and ensure that it is located/installed near the equipment and is easily accessible.

**Figure 7-1. AC Power Supply Location**

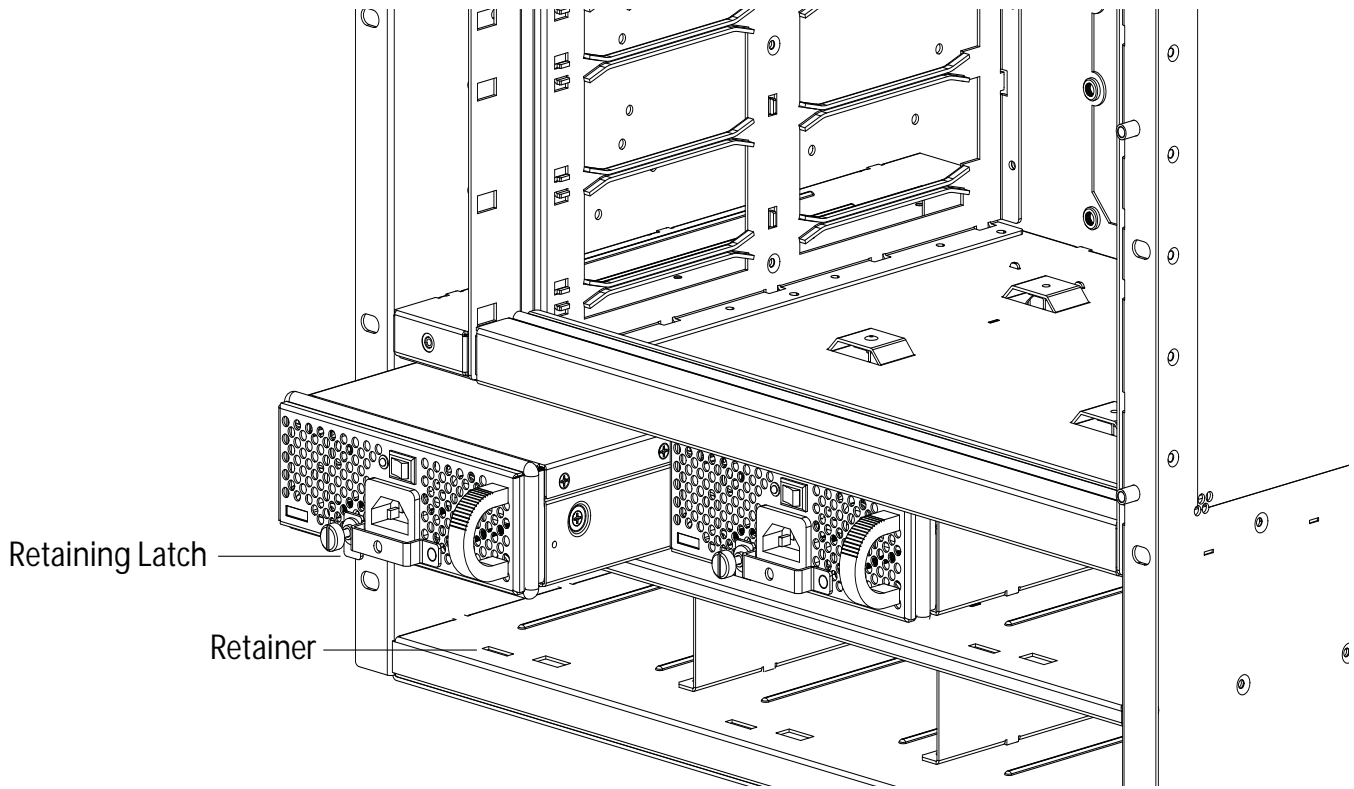

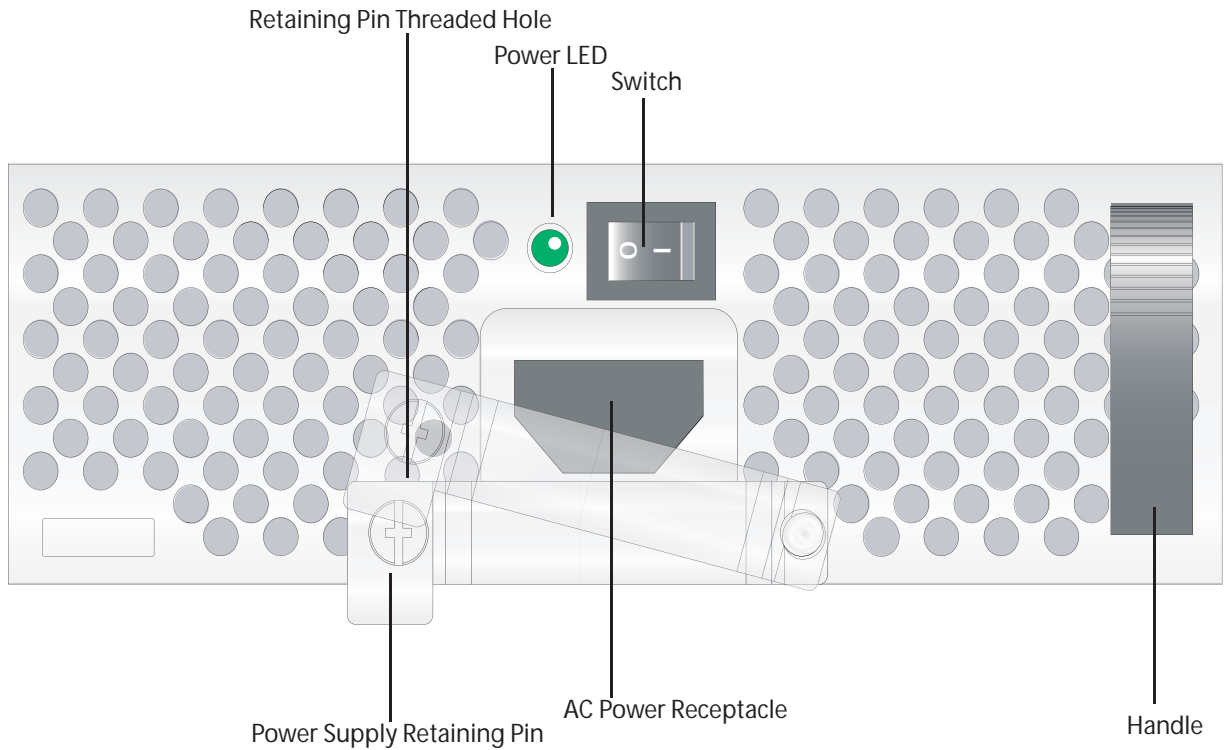

**Figure 7-2. AC Power Supply**



Each AC power supply has one LED as described in [Table 7-1](#). This LED does not function unless an RPM is installed.

**Table 7-1. AC Power Supply Unit LED Description**

Status	Description
Off	The unit is off.
Flashing Green	Warning: the unit is beyond temperature and/or current limits.
Solid Green	The unit is functioning properly
Flashing Red	The unit has failed, possibly due to temperature or current beyond its limits.
Solid Red	The unit is switched on but either unplugged or has low input voltage.  <b>NOTE:</b> For a unit LED to light red, there must be at least one other unit operating in the chassis.

 **NOTE:** If there is a failure in the power supply, it must be replaced. Power supplies are not field serviceable.

## Power Over Ethernet

The C-Series can transmit power to Ethernet devices over the signal pairs of an Shielded Twisted Pair (UTP) cable. A maximum of 15.4 Watts (at 48 Volts) can be transmitted over a link.

The chassis transmits power to connected IEEE 802.3af-compliant devices via ports that are enabled with PoE. PoE is enabled if surplus power is available from system PSUs. If the system power requirements are fulfilled by one PSU and surplus power is available, then PoE is enabled using that single PSU.

The following tables provide a mapping between the supported PoE/PoE+ ports and the PSUs for a system configuration that contains 2 RPMs, variable speed fan tray, and 4 PoE+ Line cards

**PoE Ports per Power Supply 1600W-AC at Highline**

Power Supply Units	Max PoE Ports
1	48
2	58 (System Redundancy)
3	162
4	192
5	PoE Redundancy
6	PoE Redundancy
7	N/A
8	N/A

**PoE Ports per Power Supply 1600W-AC at Lowline**

Power Supply Units	Max PoE Ports
1	24
2	32 (System Redundancy)
3	110
4	188
5	192
6	PoE Redundancy
7	N/A
8	N/A

## Power Over Ethernet Plus (PoE+)

The C-Series can transmit power to Ethernet devices over the signal pairs of an Shielded Twisted Pair (UTP) cable. A maximum of 30.0 Watts (at 53 Volts) can be transmitted over a link. The chassis transmits power to connected IEEE 802.3at-compliant devices via ports that are enabled with PoE+. The higher power of PoE+ (30W/port) is available only with Power Supply 1600W-AC and the PoE+ line card.

**Table 7-2. Maximum PoE+ Ports Support**

Power Supply Units	Max PoE+ Ports	
	Power Supply 1600W-AC at highline	Power Supply 1600W-AC at lowline
1	24	12
2	30 (System Redundancy)	16 (System Redundancy)
3	83	56
4	136	96
5	190	136
6	192	176
7	N/A	N/A
8	N/A	N/A

## Installing Power Supply Units

 **WARNING:** Use only the AC power cord supplied with the AC power supply. Do not supply power to your C7004/C150 system until the power supplies and fan tray are installed, and RPMs and line cards have been installed.

 **NOTE:** For system input power requirements see [System Power Specifications on page 62](#).



**⚠ WARNING:** Building Supply Notice: This product relies on the building's installation for short-circuit (overcurrent) protection. Ensure that a fuse or circuit breaker no larger than 120 VAC, 15A U.S. (240 VAC, 10A international) is used on the phase conductors (all current-carrying conductors).

**⚠ ATTENTION:** Pour ce qui est de la protection contre les courts-circuits (surtension), ce produit dépend de l'installation électrique du local. Vérifier qu'un fusible ou qu'un disjoncteur de 120 V alt., 15 A U.S. maximum (240 V alt., 10 A international) est utilisé sur les conducteurs de phase (conducteurs de charge).

**⚠ WARNUNG:** Dieses Produkt ist darauf angewiesen, daß im Gebäude ein Kurzschluß- bzw. Überstromschutz installiert ist. Stellen Sie sicher, daß eine Sicherung oder ein Unterbrecher von nicht mehr als 240 V Wechselstrom, 10 A (bzw. in den USA 120 V Wechselstrom, 15 A) an den Phasenleitern (allen stromführenden Leitern) verwendet wird.

You can install any power supply into any power supply slot. Dell Networking recommends installing power supplies starting from the left side, top row of the chassis, leaving no blank slots between units.

To install an AC power supply:

Step	Task
1	Verify the switch is in the <b>OFF</b> (left) position.
2	Secure the retaining latch in the unlatched position by tightening the screw into the threaded hole (Figure 7-2).
3	Slide the power supply into the top left-most power supply slot. See Figure 7-1 for the correct orientation.
4	Plug the AC power cord into the power receptacle in the face of the power supply. See Figure 7-2 for the location of the receptacle.
5	Lower the retaining latch, and tighten it into place (Figure 7-2).
6	Plug the power cord into an AC power outlet.

## Removing AC Power Supply Units

**🔧 NOTE:** Do not remove a panel blank unless you are ready to install a power supply into that slot. After removing a power supply, immediately place a panel blank in the empty slot. Blanks are required to control airflow and electromagnetic interference.

A power supply failure is recognized by a red power LED, a lit RPM alarm LED, and, if configured, an SNMP trap. If you are operating your C7004/C150 chassis with a redundant power supply, you can install, remove, or replace a power supply without affecting system operation. If you are operating your C7004/C150 system with only one power supply, you must completely power off the system to replace a power supply.

**🔧 NOTE:** If a power supply fails, the entire unit must be replaced. There are no field serviceable parts inside the unit.

To remove an AC power supply:

Step	Task
1	Toggle the switch on the power supply to the <b>OFF</b> (left) position.
2	Disconnect the AC power cable from the AC power source and the front of the power supply.
3	Unscrew the retaining latch screw. Lift the latch, and secure it in the unlatched position by tightening the latch screw (Figure 7-2).
4	Pull the power supply out of the slot using the handle.

---

Step	Task ( <i>continued</i> )
5	If you are not replacing the power supply, insert a panel blank.

---

## Power Cord Requirements

If using a power cord other than a Dell Networking supplied power cord, the power source end of the power cord must have an appropriately sized plug that complies with your local electrical codes. Conductor size must also conform to your local electrical codes.

 **CAUTION:** The power cord is the main power disconnect device; ensure that the socket-outlet is located/installed near the equipment and is easily accessible.

## Installing DC Power Entry Modules

The C7004/C150 has six power supply slots at the front-bottom of the chassis (Figure 8-2). The slots accept either AC power supplies (PSUs) or DC Power Entry Modules (PEMs). Dell Networking does not support the use of a combination of AC and DC.

- If you select DC, the C7004/C150 requires at least one DC PEM for operation, but Dell Networking recommends a one-plus-one redundancy configuration. Those DC PEMs are inserted in slots 0 and 2.
- To protect against high-voltage shock, install a power supply blank on all unused power supply slots.

**NOTE:** The C7004/C150 DC Power Entry Module does not support PoE or PoE+ line cards.

**NOTE:** Some C7004/C150 chassis may require Dell Networking assistance when using some DC power supplies. Please contact the Dell Networking TAC if you experience any difficulty during installation.

## Recommended Normal Operating Conditions

**Table 8-1. Input voltage**

Input Ranges	Maximum Power
-44V (minimum)	1408 watts
-48V (typical)	1536 watts
-55V (maximum)	1760 watts

**Table 8-2. Operating Ranges**

Ambient Temperature	
Operating Range	-5° C to +40° C
Storage Range	-40° C to +70 ° C
Humidity	
Operating Range	5-85% RH
Storage Range	5-90% RH

## Redundancy

For full facility redundancy, install two DC PEMs. Each PEM must be attached to an independent power source with a dedicated circuit breaker sized in accordance with your local building and electrical safety codes.

## Cable and Connector Requirements

You must provide your own cables to connect to a remote power source (a circuit breaker panel, for example) in your equipment rack or facility. Cables must be sized to meet the following criteria:

- Rated for 60A service to allow for a fully loaded C7004/C150 system per NEC in the United States or internationally, per local safety codes.
- Limit voltage drop across the cable length to 0.5V or less.

Apply a coat of anti-oxidant paste to unplated metal contact surfaces before you make the cable connections. File unplated connectors, braided straps, and bus bars to a shiny finish. It is not necessary to file and coat tinned, solder plated, or silver-plated connectors or other plated connection surfaces, such as those on the PEM studs.

**NOTE:** Take precautions against over-tightening the screws or nuts on this device.

**Figure 8-1. DC PEM Faceplate**

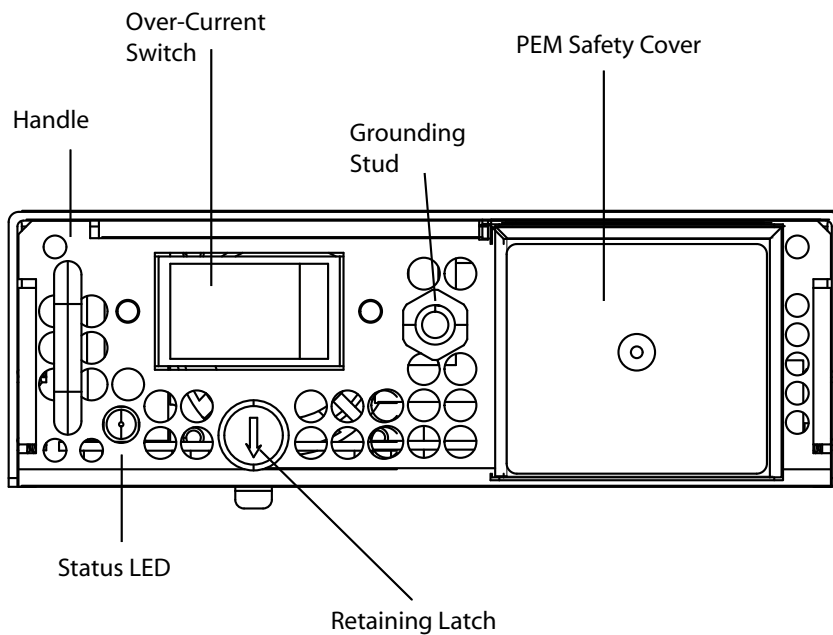

## Installing a DC PEM



Step	Task
1	Turn the remote power source (the circuit breaker panel) to the <b>OFF</b> position.
2	Turn the over-current switch (located on the PEM front panel) to the <b>OFF</b> position.
3	Loosen the PEM safety cover retaining screw and remove the cover (Figure 8-1).

Step	Task (continued)
4	Slide the PEM into either power slot 0 or 2 (see <a href="#">Figure 8-2</a> ). If you are installing redundant PEMS, install in both slots 0 and 2.

 **NOTE:** Fill all empty slots with blank panels (power supply blank).

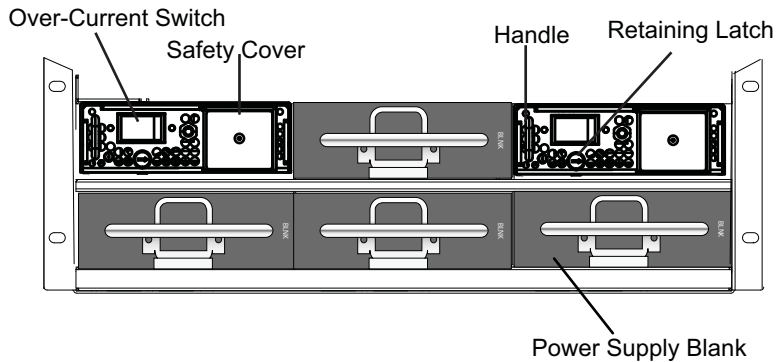
**Figure 8-2. Insert 2 DC PEMs in Slots 0 and 2**



5	Secure the PEM in place by tightening the retaining latch on each module so that the arrow points down ( <a href="#">Figure 8-1</a> ).
6	<p>Secure the chassis ground connection:</p> <p> <b>WARNING:</b> You must complete the ground connection before proceeding with any other PEM connection. Locate the chassis ground connector stud on the PEM front panel (see <a href="#">Figure 8-3</a>). It is the single stud below the safety cover.</p> <p>Remove the nut and washer from the ground stud.</p> <p>Apply a coat of anti-oxidant paste to the connector stud, if required.</p> <p>Install the grounding cable. <b>This cable is typically green or green and yellow.</b></p> <p> <b>NOTE:</b> Termination points require UL-listed 1-hole lug with a 1/4-inch hole.</p> <p>Replace the washer and nut on the stud.</p> <p>Secure the nut with a nut driver or torque wrench (not to exceed 4 ft/lbs).</p> <p>Connect the opposite end of the grounding cable to the appropriate nearest grounding.</p>
7	Remove the outer nuts and washers from each of the remaining studs.

Step	Task (continued)
8	<p>Connect the -48 VDC and Return cables from each PEM to the remote power sources.</p> <p>Verify that the remote power source is in the <b>OFF</b> position.</p> <p>Locate the appropriate studs on the PEM front panel.</p> <ul style="list-style-type: none"> <li>• The two right-handed studs (furthest from the GND) are the return (+48V DC) connection. <b>The cable attached to these studs is typically red.</b></li> <li>• The two left-handed studs (closest to GND) are the -48 V DC connection. <b>The cable attached to these studs is typically black.</b></li> </ul> <p><b>NOTE:</b> Power cables must be terminated only with a UL-listed 2-hole lug to accommodate 1/4-inch studs with 3/4-inch spacing.</p> <p>Apply a coat of anti-oxidant paste to the connector studs, if required.</p> <p>Replace the washers and nuts on the studs.</p> <p>Route the terminated cables out toward the rack rail.</p> <p>Cables will route down toward the floor. You can then route them as best suits your environment.</p> <p>Secure the nuts with a nut driver or torque wrench (not to exceed 4 ft/lbs).</p>

**Figure 8-3. Grounding**

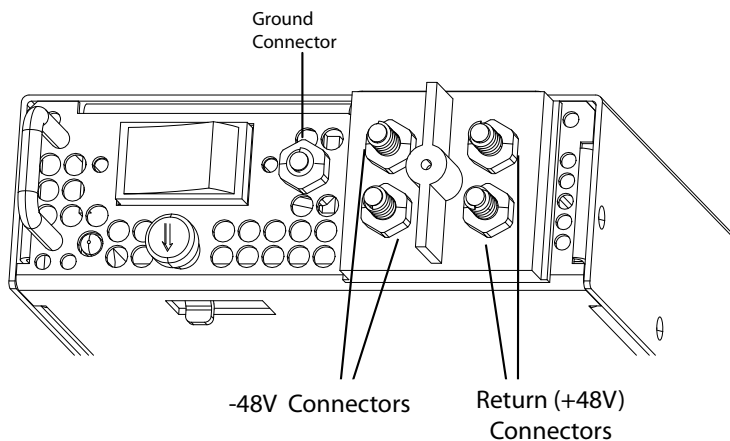

Step	Task (continued)
9	<p>Replace the safety cover and tighten the captive screw.</p> <p>Note that the safety cover can be rotated to accommodate system configurations.</p>
10	<p>Turn the Over-Current Protector to the <b>ON</b> position (<a href="#">Figure 8-1</a>).</p>
11	<p>Turn the remote power source (the circuit breaker panel) to the <b>ON</b> position.</p>

# Status LED

The status LED indicates the condition of the PEM.

**Table 8-3. Status LED Descriptions**

LED Display	Meaning	Description
Off	Off	No input voltage is present, or the circuit is turned off.
Flashing Green	Over-Current Warning	The load current is above the warning level threshold. This warning takes precedence over the temperature warning.
Flashing Green	Over-Temperature Warning	The temperature is above the temperature warning threshold.
Solid Green	Power On	The PEM is running normally.

## Removing a DC PEM

The left chassis PEM slot is labelled “0” and the right chassis PEM slot is labelled “1.” For full redundancy, each PEM must be attached to a dedicated circuit breaker. For example, PEM “0” connects to circuit breaker “0” and PEM “1” connects to circuit breaker “1.”

 **WARNING:** Prevent exposure and contact with hazardous voltages. Do not attempt to operate this system with the safety cover removed.

Step	Task
1	Switch the Over Current Protector (located on the PEM front panel) to the <b>OFF</b> position.
2	Turn off power to the PEM. Ensure that the remote power source is in the <b>OFF</b> position and that the PEM <b>Status</b> LED and <b>Pwr In OK</b> LED are off.
3	Loosen the retaining screw and remove PEM safety cover (see <a href="#">Figure 8-1</a> ).
4	Disconnect power cables attached to the PEM.
5	Slide the PEM out of the slot.
6	If you are not replacing the PEM, close the empty slot with a blank panels (power supply blank).





## Powering Up

Before you supply power to the chassis, Dell Networking recommends that you re-inspect your equipment rack and chassis. Verify that:

- The equipment rack is properly secured and grounded.
- The chassis is bolted and secured into your equipment rack.
- Make sure the ambient temperature around the unit (which may be higher than the room temperature) is within the limit specified for the unit.
- Make sure there is sufficient airflow around the unit.
- Make sure electrical circuits are not overloaded – consider the nameplate rating of all the connected equipment, and make sure you have over current protection.
- At least one power supply module is installed.
- All power supply modules are properly installed.
- All power supply modules are switched to the **OFF** (left) position.
- The remote power source complies with the input power specifications in the section [System Power Specifications on page 62](#).
- AC Power cables connect to the remote power source (if applicable).
- The fan tray is installed and cannot be removed by pulling on the fan tray handle.
- At least one RPM is installed.
- All line cards and RPMs are properly installed and secured.
- All chassis slots are filled. Blank panels and covers are installed in all empty slots.
- Make sure no objects are placed on top of the unit.

To supply power to the C7004/C150 system:

 **WARNING:** Never operate the C7004/C150 System without a fan tray.

Step	Task
1	Verify that the power source complies with the system input power requirements in the section <a href="#">System Power Specifications on page 62</a> .
2	Energize the remote power source or outlet.
3	Toggle the switch on the AC power supplies to the <b>ON</b> (right) position.

Step	Task
4	In an AC power supply, the LEDs should be green. If these LEDs are not lit green: <ul style="list-style-type: none"> <li>• Check that the unit is properly installed.</li> <li>• Verify the power source.</li> <li>• If the power supply cannot be verified, power off all modules and replace the unit.</li> </ul>
5	The fan tray LED should be green (online). You should be able to hear the air flowing through the chassis. If the fans are not operating properly or air is not flowing through the chassis: <ul style="list-style-type: none"> <li>• Power off all power supplies.</li> <li>• Verify that the fan tray is properly installed.</li> <li>• If the fan tray LED remains unlit, power down the unit, and replace the fan tray.</li> </ul>

To power down a power supply or the entire C7004/C150 system:

Step	Task
1	To power down a single power supply, toggle the switch to the <b>OFF</b> (left) position. To power down the entire system, toggle the switches on all power supplies to the <b>OFF</b> position.
2	Unplug the power cord from the power receptacle on the front of the power supply.
3	Verify that the LEDs are unlit.

After you supply power to the system, the following should occur:

- The fan tray should be operating.
- The green (online) fan tray, RPM, and line card LEDs should be lit and remain lit as long as the system is receiving power and is operational.

When you supply power to the C7004/C150, the system performs a series of power-on self tests. RPM and line card LEDs blink as the diagnostic programs run. No user interaction is required at this point. Observe the process on your console monitor. When the boot process is complete, the card LEDs remain online (green) and the console monitor displays the Command Line Interface (CLI) prompt ([Figure 9-1 on page 43](#)).

Figure 9-1. Boot Process Complete

```

                                     .*****.
                                     .#  ####  #####.
#####  #####  #####  #####  #####  .#.  #####  #####.
###    ###    ##  ###    ###  #####  ###    .##.  ##  ###  #####  ###.
###    ###    ###  ###    ###  ###    ###    *#.  ###  ###    #*
###    ###    ##  ###    #####  ###    #####  *#  -##  ###    #*
#####  ###    ##  #####  ###    #####  *#  ###  ##    #*
###    ###    ##  ###    #####  ###    ###    *#  #####  ###    #*
###    ###    ###  ###    #####  #####  ###    *#.  #####  ###    ###*
###    ###    ###  ###    ###  #####  ##  #####  .#.#####  #####  #####  .
###    #####  ###    ###  #####  #####  .#####  #####  #####  .
                                     .#  #####  .
                                     `*****'

```

Copyright 1999-2006 Force10 Networks, Inc.

```

+ Force10 Networks, Inc.
+ CPU: DB-MV64460-BP/IBM750Fx (2.3)
+ Version: VxWorks5.5.1
+ Memory Size: 1038876672 bytes.
+ BSP Version: 1.2/1.3.6
+ Creation Date : Jan  2 2007

```

nvDrvInit: nvDrvErase passed

-> 00:00:10: %RPM0-U:CP %RAM-6-ELECTION\_ROLE: RPM0 is transitioning to Primary



## Fan Tray

The C7004/C150 chassis contains one field-replaceable fan tray. There are two types of fan tray that may be installed: C7004/C150 variable speed fan tray contains six fans that run at varying speeds depending on system temperature, C7004/C150 fixed speed fan tray contains six fans that run at a constant speed. For both types of trays, air flows through the C7004/C150 system toward the fans (right to left) and is exhausted on the fan-side of the chassis. The fan tray is accessible from the front of the chassis.

Contact Dell Networking Technical Support if you have questions concerning the fan tray for your system.

- NOTE: To ensure proper temperature and airflow control, the fan tray must always be installed and operating properly.
- NOTE: The C7004/C150 does not have an air filter, so take special care in making sure that the installation site and the chassis itself are cleaned regularly.

Figure 10-1. Inserting the Fan Tray

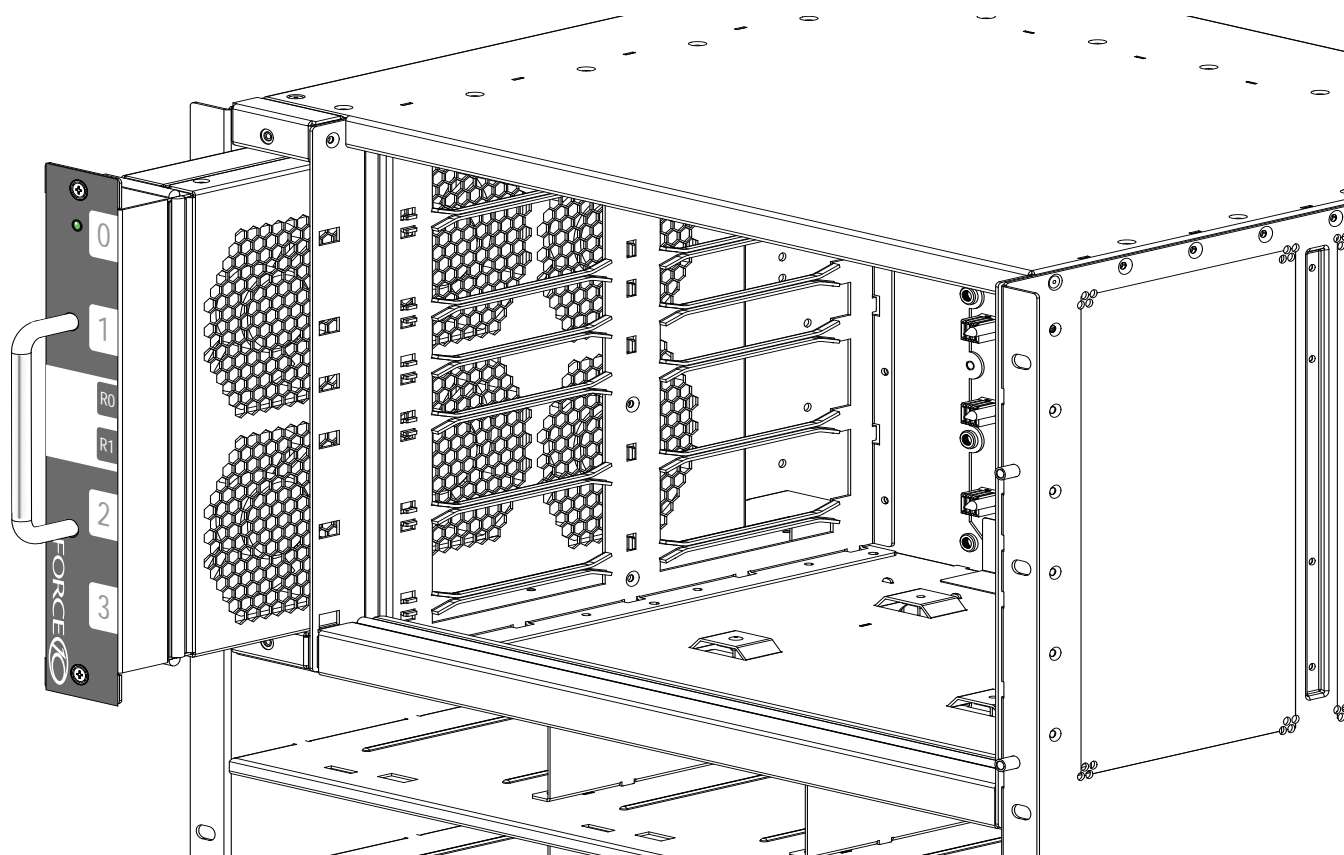

## Installing the Fan Tray

To install the fan tray:

Step	Task
1	Slide fan tray into the fan tray slot as shown in <a href="#">Figure 10-1</a> .
2	Gently push on the front of the tray until it is flush with the chassis.
3	Use a #2 Phillips screwdriver to secure the fan tray into place by tightening the screws at the top and bottom of the fan tray.

 **NOTE:** The fan tray LED remains lit when the chassis is powered up and the fan tray is functioning properly.

## Removing the Fan Tray

A fan tray failure or a failure of a fan within a fan tray is recognized by a red fan tray LED, a lit RPM alarm LED, and, if configured, an SNMP trap and alarm event. The failure requires a replacement of the entire fan tray. While you replace the fan tray, the C7004/C150 system operates safely for approximately two (2) minutes at an ambient temperature of 77° F (25° C).

To remove the fan tray, you must be able to pull the fan tray completely out of the slot (at least 20 inches).

 **WARNING:** The fan tray must always be installed to ensure proper temperature and airflow control.

 **WARNING:** Fan blades rotate at high speeds and may cause injury if touched. Adhere to the following instructions to avoid possible injury.

To remove the fan tray:

Step	Task
1	Unscrew the retaining screws at the top and bottom of the fan tray.
2	Use the handle to pull the fan tray out approximately two inches from the back of the chassis ( <a href="#">Figure 10-1</a> ). Wait 30 seconds, until the fan blades stop rotating, then completely remove the fan tray.

## Fan Speed

C7004/C150 variable speed fan is driven by temperatures measured at the sensor in the fan tray alone. The sensor is located on the fan tray controller located in the fan tray. [Table 10-1](#) shows the sensor temperature that determines the fan speed.

**Table 10-1. Fan Speed and Temperature**

Degrees Celsius	Fan Speed
Less than 45C	(Low) 2400 RPM
Between 45 and 55	(Med) 3200RPM
Above 55C	(High) 4000 RPM

C7004/C150 fixed speed fan is constant and does not change with temperature.

# Removing and Replacing Components

This section provides instructions for removing and replacing the following C7004/C150 components:

- [Removing and Replacing the Fan Tray on page 47](#)
- [Removing and Replacing Power Supply Units on page 48](#)
- [Removing and Replacing a Line Card on page 49](#)
- [Removing and Replacing an RPM on page 49](#)

When a component fails, the C7004/C150 System system triggers an alarm LED (located on the active RPM), disables or changes component Status LEDs, and sends events to the SNMP trap and show alarms table (if this feature is configured). Refer to [Appendix , Alarms, on page 57](#) for more information on alarms.

 **NOTE:** Always wear an ESD-preventive wrist or ankle strap when handling RPMs and line cards. Connect the ESD strap to the grounding plug located on the front of the chassis. Place RPMs and line cards on an antistatic surface and anti-static bags when they are not installed. Electrostatic discharge (ESD) damage can occur when components are mishandled.

When a component fails, the C7004/C150 System system triggers major or minor alarm LEDs (located on the RPM), sends events to the SNMP trap and show alarms table, disables or changes component Status LEDs or triggers an audible alarm. Refer to [Appendix , Alarms, on page 57](#) for more information on alarms.

## Removing and Replacing the Fan Tray

A fan tray failure or a failure of a fan within a fan tray is recognized by a red fan tray LED, a lit RPM alarm LED, and, if configured, an SNMP trap and alarm event. The failure requires a replacement of the entire fan tray. While you replace the fan tray, the C7004/C150 system operates safely for approximately two (2) minutes at an ambient temperature of 77° F (25° C).

To remove and replace the fan tray, you must have enough space to pull the fan tray completely out of the slot (at least 20 inches).

 **WARNING:** Fan blades rotate at high speeds and may cause injury if touched. Adhere to the following instructions to avoid possible injury.

 **NOTE:** The fan tray must always be installed to ensure proper temperature and airflow control.

To remove and replace the fan tray:

Step	Task
1	Unscrew the retaining screws at the top and bottom of the fan tray.
2	Use the handle to pull the fan tray out approximately two inches from the back of the chassis. Wait 30 seconds, until the fan blades stop rotating, then completely remove the fan tray.

Step	Task
3	Insert the new fan tray into the chassis. Guide the tray firmly into the slot until the fan tray is flush with the chassis.
4	Secure the fan tray into place by tightening the screws at the top and bottom of the fan tray using a #2 Phillips screwdriver.

## Removing and Replacing Power Supply Units

**⚠ WARNING:** Do not remove a panel blank unless you are ready to install a power supply into that slot. After removing a power supply, immediately place a panel blank in the empty slot. Blanks are required to control airflow and electromagnetic interference.

A power supply failure is recognized by a red power LED, a lit RPM alarm LED, and, if configured, an SNMP trap. If you are operating your C7004/C150 chassis with a redundant power supply, you can install, remove, or replace a power supply without affecting system operation. If you are operating your C7004/C150 system with only one power supply, you must completely power off the system to replace a power supply.

**🔧 NOTE:** If a power supply fails, the entire unit must be replaced. There are no field serviceable parts inside the unit.

To remove and replace a power supply:

Step	Task
1	If you are removing one of only two installed power supplies, power down the chassis (see <a href="#">Powering Up on page 41</a> ). If you are removing a redundant power supply, toggle the switch on the power supply to the <b>OFF</b> (left) position.
2	If applicable, disconnect the power cable from the AC power source and the front of the power supply.
3	If using a DC PEM, turn the remote power source (the circuit breaker panel) and the over-current switch (located on the PEM front panel) to the <b>OFF</b> position.
4	Pull the power supply out of the slot using the handle.
5	If you are not replacing the power supply, insert a panel blank.
6	Toggle the switch on the replacement power supply to the <b>OFF</b> position.
7	Slide the new power supply into the power supply slot. See <a href="#">Figure 7-1</a> for the correct orientation.
8	If applicable, plug the power cord into the power receptacle in the face of the power supply. See <a href="#">Figure 7-2</a> for the location of the receptacle and plug the AC power cord into an AC power outlet
9	If using a DC PEM, secure it in place by tightening the retaining latch on each module so that the arrow points down.
10	On the DC PEM, secure the chassis ground connection and connect the -48 VDC and Return cables from each PEM to the remote power sources. See <a href="#">Figure 8-3</a> for correct connections.
11	Toggle the switch on the power supply to the <b>ON</b> (right) position.
12	Power up the chassis if necessary.



## Removing and Replacing a Line Card

**⚠ WARNING:** Do not remove a panel blank unless you are ready to install a line card into that slot. After removing a line card, immediately place a panel blank in the empty slot. Blanks are required to control airflow and electromagnetic interference.

You can add, replace, or remove C7004/C150 line cards without interrupting the system power or system operations.

To remove and replace C7004/C150 line cards:

Step	Task
1	Unplug the network interface cables connected to the line card.
2	Extend the left and right card levers by first pressing gently down on the thumb tabs (Figure 11-1) in the ejector levers and then pulling the ejector levers simultaneously until they are in the open position, as shown in Figure 11-2.

**Figure 11-1. Depressing the Thumb Tabs**

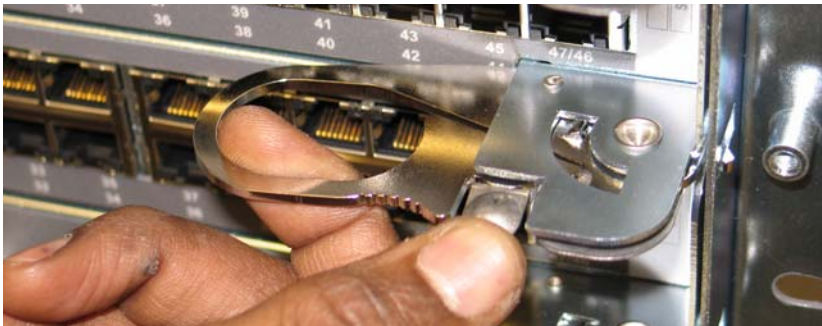

**Figure 11-2. Extending the Levers**



- 3 Pull the card by the card levers until it is out of the slot. Avoid touching the printed circuit board and connector pins.
- 4 If you are not replacing the card immediately, install a blank panel.
- 5 If you are replacing the card, follow the instructions in [Installing RPMs and Line Cards on page 21](#).

## Removing and Replacing an RPM

**⚠ WARNING:** After removing an RPM, place a panel blank in the empty slot before powering up the chassis. Blanks are required to control airflow and electromagnetic interference.

**NOTE:** The C7004/C150 requires at least one RPM to operate. The chassis powers down if you remove the only RPM.

To remove and replace a C7004/C150 RPM:

Step	Task
1	Unplug any network interface cables connected to the RPM.
2	Extend the left and right card levers by first pressing gently down on the thumb tabs (see <a href="#">Figure 11-3</a> ) in the ejector levers and then pulling the ejector levers simultaneously until they are in the open position. See <a href="#">Figure 11-4</a> .

**Figure 11-3. Depressing the Thumb Tabs**

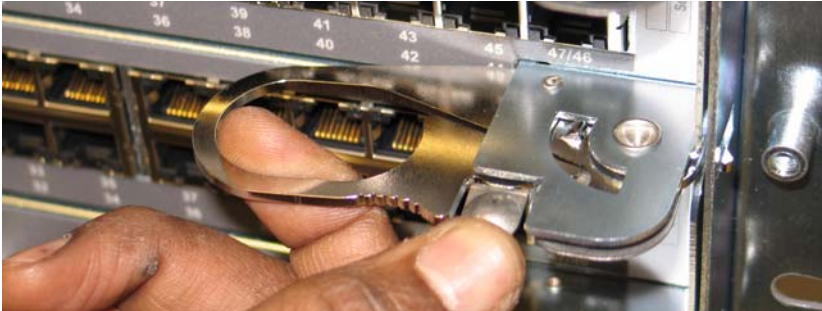

**Figure 11-4. Extending the Levers**



- 3 Pull the card by the card levers until it is out of the slot. Avoid touching the printed circuit board and connector pins.
- 4 If you are not replacing the RPM, insert an RPM blank panel.
- 5 If you are replacing the RPM, follow the instructions in [Installing RPMs and Line Cards on page 21](#).

## System Boot

When you supply power to the C7004/C150 system, the system performs a series of power-on self-tests. RPM and line card status LEDs blink during initialization. No user interaction is required as long as the boot process proceeds without interruption. Observe the process on your console monitor. When the boot process is complete, the RPM and line card status LEDs remain online (green) and the console monitor displays the command line interface (CLI) prompt, Force10>.

The RPM cards in the C7004/C150 system use a Compact Flash Card (external flash memory card) to store and retrieve boot and system images. This is the default storage area for the boot files and the startup configuration file. Upon system power-up or a system reset, the boot process uses parameters stored in non-volatile random access memory (NVRAM) to boot the system.

Each RPM card is equipped with a slot for an external flash memory card (slot0:). You can copy the image files and configuration files to the external flash device on the *primary* RPM. You can also begin your boot process by accessing a remote server containing the boot image and system image files.

 **NOTE:** The C7004/C150 system supports up to a 40-character file name length, up to a 180-character local file path length, and up to a 256-character remote file path length.

For information about the Compact Flash Card, refer to [Appendix , , on page 55](#).

For information about the flash memory card, refer to [Appendix , , on page 55](#).

### Booting from the BOOT\_USER Prompt

To get into the BOOT\_USER mode, issue a break control sequence (CNTRL+^ ) to interrupt the automatic boot process; you may enter the mode if you experience boot problems. This mode allows you to modify the parameters necessary to manage the boot process. Only console port access is enabled for the BOOT\_USER mode.

The BOOT\_USER # prompt appears after an autoboot interruption. This is the default boot prompt, not the CLI prompt.

In some display outputs, you can continue the help screen display by pressing ENTER or stop the output by entering **q** and then ENTER. You can abbreviate the boot commands by entering only the first letter of a command word. (In the BOOT\_USER mode, you cannot press the TAB key to complete commands.) A matching algorithm displays the commands, starting with the letter or letters you entered. For example, **b** displays the commands starting with the letter b, **boot change** and **boot selector**. Entering **s h** displays the **syntax help** information. All commands are case-insensitive.

To configure the chassis from the BOOT\_USER prompt use the following commands:

Command	Purpose
help	<ul style="list-style-type: none"> <li>• Enter <code>help</code> or <code>?</code> to display a list of available commands and syntax.</li> </ul>
or	<ul style="list-style-type: none"> <li>• Enter <code>syntax help</code> to display syntax information and variable descriptions.</li> </ul>
?	
boot change {primary   secondary   default}	<p>If your configuration displays no pre-configured operating system boot parameters, use the <code>boot change</code> command to edit appropriate fields.</p> <ul style="list-style-type: none"> <li>• The <code>primary</code> operating system boot parameters are used in the first attempt to boot the system.</li> <li>• The <code>secondary</code> operating system boot parameters are used if the primary operating system boot selection is not available.</li> <li>• The <code>default</code> operating system boot parameters are used if the secondary operating system boot parameter selection is not available. The default parameters always reside on the internal flash device (flash:).</li> </ul> <p><b>NOTE:</b> These parameters, as well as other boot parameters, can be modified in the run-time mode.</p> <p>When you enter the <code>boot change</code> command, you are prompted for a response.</p> <ul style="list-style-type: none"> <li>• Enter a new parameter or press the ENTER key (carriage return) to accept the default parameter.</li> <li>• Enter <code>.</code> (period) to clear a field.</li> <li>• Enter <code>-</code> (dash) to edit a field above the current cursor position.</li> </ul> <p><b>NOTE:</b> When you enter a new parameter that extends beyond 80 characters, you cannot use the BACKSPACE key to correct any mistakes. If you make a mistake, you must re-enter the parameter.</p>

```

BOOT_USER # boot change primary

',' = clear field; '-' = go to previous field

boot device           : flash
file name             : /FTOS-CB-1.1.x.y.bin

BOOT_USER # boot change default

',' = clear field; '-' = go to previous field

boot device           : flash
file name             : /FTOS-CB-1.1.x.y.bin

BOOT_USER #

```

Command	Purpose (continued)
show bootvar	This command displays the current operating system boot configuration parameters.

```
BOOT_USER # show bootvar
```

```
PRIMARY OPERATING SYSTEM BOOT PARAMETERS:
```

```
=====
```

```
boot device           : flash
file name             : /FTOS-CB-1.1.x.y.bin
```

```
SECONDARY OPERATING SYSTEM BOOT PARAMETERS:
```

```
=====
```

```
No Operating System boot parameters specified!
```

show bootflash	This command displays information about the current boot ROM.
----------------	---

```
BOOT_USER # show bootflash
```

```
GENERAL BOOTFLASH INFO
```

```
=====
```

```
Bootflash Partition A:
```

```
Forcel0 Networks System Boot
Copyright 1999-2007 Forcel0 Networks, Inc.
ROM Header Version 1.1
Engineering 750_64460_CP_IMG_BOOT_CS, BSP Release 1.0.0.52, Checksum
0x3a531c11
Created Fri Jan 12 15:05:47 2007 by build on hydrogen
Trailer Version 1.0 001deaa8
Trailer checksum 0x3a531c11
```

```
Bootflash Partition B:
```

```
Forcel0 Networks System Boot
Copyright 1999-2007 Forcel0 Networks, Inc.
ROM Header Version 1.1
```

Command	Purpose (continued)
interface management port config 100m	• Use these commands to set the speed and duplex settings for the Management interface. The default setting is full-duplex and auto-negotiation.
interface management port config 10m	• Use the interface management port config show command to view the Management interface's physical settings.
interface management port config auto-negotiate	
interface management port config no auto-negotiate	
interface management port config full-duplex	
interface management port config half-duplex	
interface management port config show	
show interface management ethernet	• Use the show interface management ethernet command to display the IP address and network mask of the management Ethernet port.
interface management ethernet ip address <i>ip-address ip-address- mask</i>	• If the show command output does not display configured IP address information, use the interface management ethernet ip address <i>ip-address ip-address-mask</i> command to set the IP address of the Management Ethernet port for network (ftp/tftp) operating system boot. Use CIDR block notation for the subnet mask.

```

BOOT_USER # show interface management ethernet
No IP address set for interface management ethernet 0/0!

BOOT_USER # interface management ethernet ip address 1.2.3.4/24
Management ethernet 0/0 IP address: 1.2.3.4/24

```

boot zero {default | primary | secondary} Delete the boot configuration.

reload

Reload software.

The autoboot program initializes and displays self-test results on the console screen.

 **NOTE:** Do not press break control sequence at any time during the boot/reboot process. Doing so causes the boot process to terminate.

Refer to the *Dell Networking OS Command Line Interface Reference* for BOOT\_USER mode commands and commands for run-time modes.

## The Compact Flash Card

Each RPM is designed with a slot (slot0:) to accommodate a Compact Flash card (external Compact Flash memory card). You can use the Compact Flash card to store and retrieve boot and system images. For complex configurations, you can copy your configurations onto the Compact Flash card and then transfer the configuration to other C7004/C150 systems in your network. Dell Networking supports up to a 40-character file name length, up to a 180-character local file path length, and up to a 256-character remote file path length.

**NOTE:** Use only a Dell Networking Compact Flash card in your C7004/C150 System. Additional cards can be purchased from Dell Networking.

### Inserting the Compact Flash Card

**NOTE:** Insert the Compact Flash card either before system boot or after the system has completed booting and is in run-time mode.

To install the Compact Flash card:

Step	Task
1	Hold the Compact Flash card horizontally with the side containing the serial number facing up (the numbers should be oriented so you can read them). See <a href="#">Figure 13-1</a> for the proper orientation.

**Figure 13-1. Inserting the Compact Flash Card in RPM**

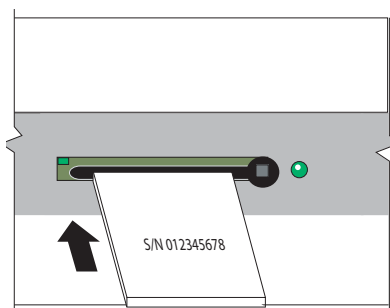

- 2 Insert the Compact Flash card into the primary RPM flash slot until the card is completely seated with the connectors at the rear of the slot.

**NOTE:** Do not force the Compact Flash card into the slot. The slot is designed to prevent improper installation. The In Use LED lights only during read or write operations.

### Removing the Compact Flash Card

**WARNING:** Do not remove the Compact Flash card when the In Use LED is lit.

To remove the flash memory card:

---

Step	Task
1	Make sure that the In Use LED is not lit, and gently depress the flash card in the slot. The card should partially eject out of the slot.
2	Remove the card, and place it in an antistatic bag.

---

## Formatting the Compact Flash Card

New Compact Flash cards must be formatted in the C7004/C150 before use.

Flash cards used on systems other than the C7004/C150, as well as cards formatted on PCs, must be reformatted in the C7004/C150 flash slot before they can be used. Formatting erases all information stored on the flash card.

To format the Compact Flash card:

---

Step	Task
1	Insert the flash card into the flash slot on the primary RPM.
2	Enter the command <b>format slot0:</b>

---



# Alarms

The C7004/C150 system generates alarms for the following conditions:

- fan tray status
- power supply status
- RPMs status
- high temperature on RPMs
- line cards status
- high temperature on line cards

A *major alarm* is any fault that would render the C7004/C150 system non-functional.

A *minor alarm* is any fault that threatens the operation of the C7004/C150 system.

You can monitor alarm conditions on the C7004/C150 system through the console and LEDs. If you configure the SNMP command `snmp-server enable traps envmon`, Dell Networking OS also sends an SNMP trap.

In the C7004/C150 system, alarms are logged for each occurrence, but the system may not send an event log for multiple occurrences. For example, whenever a module exceeds the shutdown threshold, the module shuts down.

If more than one module exceeds the warning or high-temperature thresholds within a five-minute period, the system generates one event for all affected modules, but alarms are logged for each occurrence. If the module temperature falls to 5° lower than the warning threshold temperature, the system clears the alarm and an SNMP trap.

**Table A-1. Alarm Events and Reporting**

Module	Alarm Event	Alarm LED	Reported in event log	Status LED on Module
Fan tray	One fan within the module fails.	minor (blinking red)	minor	N/A
	More than one fan within the module fails or hardware failure in the module.	major (red)	major	unlit
AC power supplies	Hardware failure in a non-redundant power configuration (two power supplies)	major (red)	major	unlit
	Hardware failure in a redundant power configuration (three or more)	minor (amber)	minor	unlit

**Table A-1. Alarm Events and Reporting**

Module	Alarm Event	Alarm LED	Reported in event log	Status LED on Module
Line card	Hardware failure	major (red)	major	amber
	Exceeds high-temperature limit	major (red)	major	unlit
	Exceeds warning temperature limit	minor (amber)	minor	green
	Individual interface fails	minor (amber)	reported	amber <sup>a</sup>
RPM (Non-redundant Configuration with 1 RPM)				
	Exceeds high temperature limit	major (red)	major	unlit
	Exceeds warning temperature limit	minor (amber)	minor	green
	RPM fails but Control Processor (CP) is OK	major (red)	major	amber

<sup>a</sup>

## AC Power Supplies and Alarms

During system boot, if a redundant power supply is removed or fails, Dell Networking OS generates a minor alarm message.

If only two power supplies are installed and one of them fails, Dell Networking OS generates an alarm and an SNMP trap (if configured), and lights the RPM alarm LED and power supply LED.

# System Specifications

This appendix contains the following major sections:

- [Physical Design](#)
- [System Power Specifications on page 62](#)
- [Component Power Requirements on page 62](#)
- [Agency Compliance on page 63](#)

## Physical Design

 **NOTE:** See [Figure B-1](#) and [Figure B-2 on page 61](#) for the data used for the physical dimensions.

**Table B-1. Chassis Dimensions**

Parameter	Specifications
Height	15.7 inches (39.88 cm)
Width	17.5 inches (44.45 cm)
Depth	15.3 inches (38.86 cm)
Weight	38 lbs (17.24 kg) with factory installed components 86.63 lbs (39.29 kg) fully loaded
Mounting	Integral rack mount strips for front mounting in a standard 19-inch rack.
Clearance required	Front: 18 inches (46 cm) Rear: 18 inches (46 cm)

Figure B-1. Chassis Dimensions Length/Width

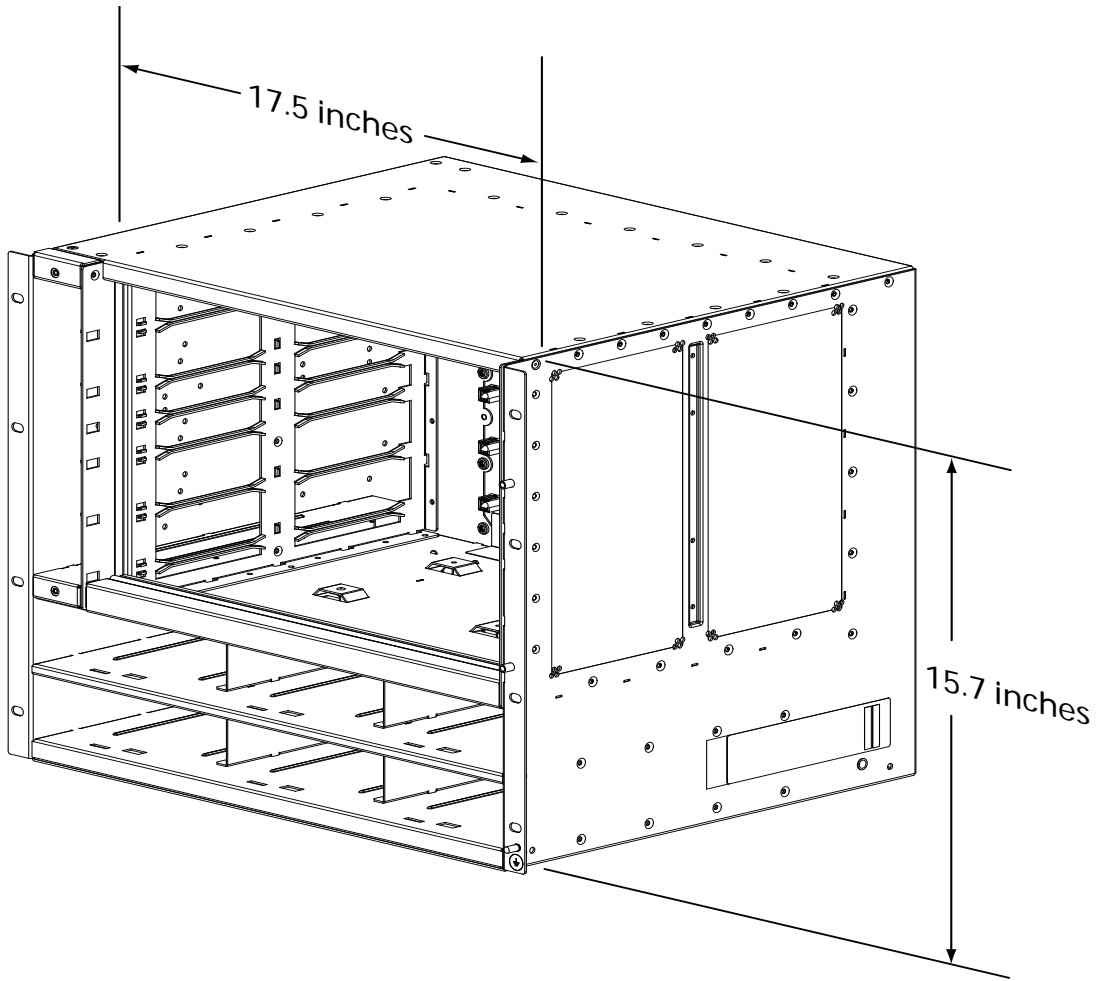
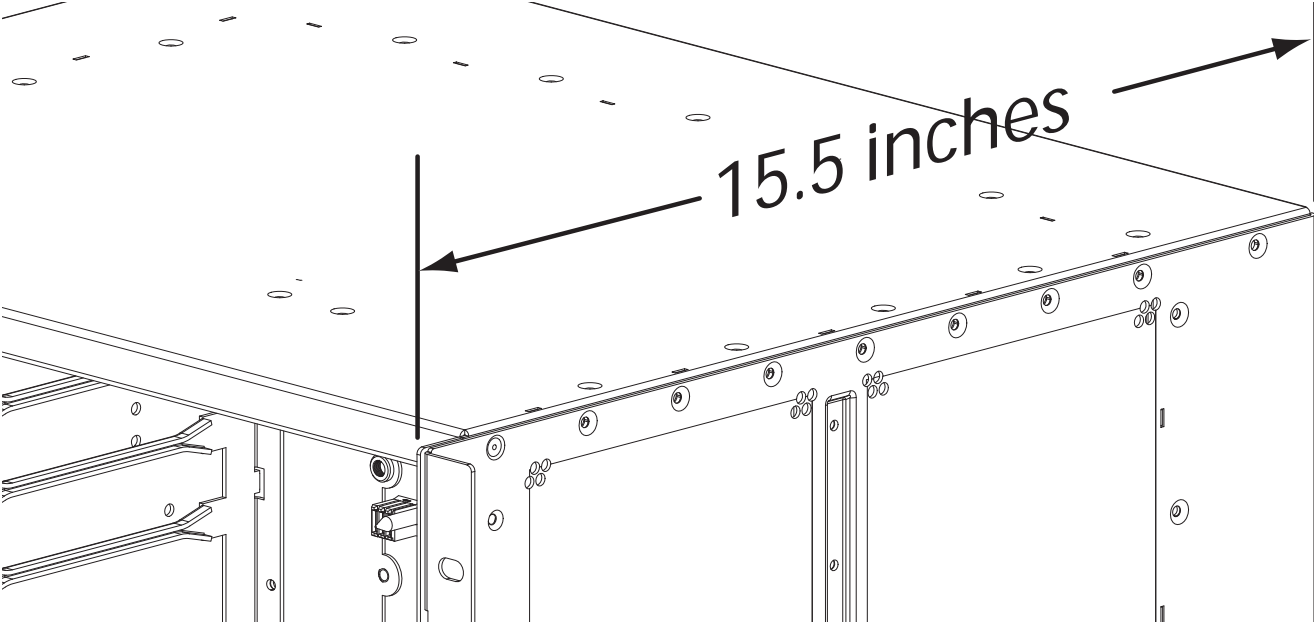

Figure B-2. Chassis Dimensions Depth



# System Power Specifications

**Table B-2. Power Supply 1600W-AC**

Parameter	C7004/C150 Specifications
Nominal input voltage	100-240 V 50/60 Hz
Maximum AC Power Supply Input Current (Based on 1200 W output for 100/120 V and 1600 W output 200/240 V lines)	14 A @ 100 V per AC Power Supply 11 A @ 120 V per AC Power Supply 9 A @ 200 V per AC Power Supply 7 A @ 240 V per AC Power Supply
Maximum System Power Input	6,897 KVA @ 100/120 V 7,315 KVA @ 200/240 V
Maximum power consumption	1,647 W @ 100/120 V 1,555 W @ 200/240 V
Maximum Thermal Output at 100/120 V	5,618 BTU/hour
Maximum Thermal Output at 200/240 V	5,304 BTU/hour

**Table B-3. Power Supply 1200W-AC**

Parameter	C7004/C150 Specifications
Nominal input voltage	100-240 V 50/60 Hz
Maximum AC Power Supply Input Current (Based on 1200 W output for both 100/120 V and 200/240 V lines)	14 A @ 100 V per AC Power Supply 11 A @ 120 V per AC Power Supply 7 A @ 200 V per AC Power Supply 6 A @ 240 V per AC Power Supply
Maximum System Power Input	4,261 KVA @ 100/120 V 4,165 KVA @ 200/240 V
Maximum power consumption	1,304 W @ 100/120 V 1,208 W @ 200/240 V
Maximum Thermal Output at 100/120 V	4,449 BTU/hour
Maximum Thermal Output at 200/240 V	4,122 BTU/hour

## Component Power Requirements

**Table B-4. Component Power Requirements**

Component	Maximum Watts
48 Port 10/100/1GE-POE+	105W
48-port 10/100/1GELine Card	100W
4-port 10G XFP Line Card	120W
8-port 10G XFP Line Card	120W
8-port 10G SFP+ Line Card	120W
48-port 1G SFP Line Card	130W
48-port 10/100/1GE PoE Line Card	100W

**Table B-4. Component Power Requirements**

Component	Maximum Watts
46-port FlexMedia Line Card	120W
46-port FlexMedia PoE Line Card	120W
16-port 10GE Line Card	120W
6-port 40G QSFP Line Card	110W
C7004/C150 RPM	100W
Fixed speed fan tray	50W
Variable speed fan tray	80W
Power Supply Unit 1200W-AC	1200W
Power Supply Unit 1600W-AC	1200W (low-line) 1600W (high-line)

 **NOTE:** The listed requirement for the PoE version of line cards excludes the required power for PoE, as that requirement is a function of the number and type of PoE devices connected.

## Agency Compliance

The C7004/C150 system is designed to comply with the following requirements.

**USA FEDERAL COMMUNICATIONS COMMISSION (FCC) STATEMENT** — This equipment has been tested and found to comply with the limits for a Class A digital device, pursuant to Part 15 of the FCC rules. These limits are designated to provide reasonable protection against harmful interference when the equipment is operated in a commercial environment. This equipment generates, uses, and can radiate radio frequency energy. If it is not installed and used in accordance to the instructions, it may cause harmful interference to radio communications. Operation of this equipment in a residential area is likely to cause harmful interference, in which case users will be required to take whatever measures necessary to correct the interference at their own expense.

Properly shielded and grounded cables and connectors must be used in order to meet FCC emission limits. Dell Networking is not responsible for any radio or television interference caused by using other than recommended cables and connectors or by unauthorized changes or modifications in the equipment. Unauthorized changes or modification could void the user's authority to operate the equipment.

This device complies with Part 15 of the FCC Rules. Operation is subject to the following two conditions: (1) this device may not cause harmful interference, and (2) this device must accept any interference received, including interference that may cause undesired operation.

— CANADIAN DEPARTMENT OF COMMUNICATION STATEMENT —

### Industry Canada Class A emission compliance statement

This Class A digital apparatus complies with Canadian ICES-003.

### Avis de conformité à la réglementation d'Industrie Canada

Cet appareil numérique de la classe A est conforme à la norme NMB-003 du Canada.

### EUROPEAN UNION EMC DIRECTIVE CONFORMANCE STATEMENT —

This product is in conformity with the protection requirements of EU Council Directive 2004/108/EC on the approximation of the laws of the Member States relating to electromagnetic compatibility. Dell Networking can not accept responsibility for any failure to satisfy the protection requirements resulting from a non-recommended modification of this product, including the fitting of non-Dell option cards.

This product has been tested and found to comply with the limits for Class A Information Technology Equipment according to CISPR 22/ European Standard EN 55022. The limits for Class A equipment were derived for commercial and industrial environments to provide reasonable protection against interference with licensed communication equipment.

 **CAUTION:** This is a Class A product. In a domestic environment, this device may cause radio interference, in which case, the user may be required to take adequate measures.

## EUROPEAN COMMUNITY CONTACT —

Dell Force10, EMEA - Central  
 Dahlienweg 19  
 66265 Heusweiler  
 Germany

<http://www.force10networks.com/german/>

Tel: +49 172 6802630

Email: EMEA Central Sales

## JAPAN: VCCI COMPLIANCE FOR CLASS A EQUIPMENT —

この装置は、情報処理装置等電波障害自主規制協議会（VCCI）の基準に基づくクラスA情報技術装置です。この装置を家庭環境で使用すると電波妨害を引き起こすことがあります。この場合には使用者が適切な対策を講ずるよう要求されることがあります。

This is Class A product based on the standard of the Voluntary Control Council For Interference by Information Technology Equipment (VCCI). If this equipment is used in a domestic environment, radio disturbance may arise. When such trouble occurs, the user may be required to take corrective actions.

**⚠ WARNING:** AC Power cords are for use with Dell Networking equipment only, do not use Dell Networking AC Power cords with any unauthorized hardware.

本製品に同梱いたしております電源コードセットは、本製品専用です。本電源コードセットは、本製品以外の製品ならびに他の用途でご使用いただくことは出来ません。製品本体には同梱された電源コードセットを使用し、他製品の電源コードセットを使用しないで下さい。

— This is Class A product based on the standard of the Voluntary Control Council For Interference by Information Technology Equipment (VCCI). If this equipment is used in a domestic environment, radio disturbance may arise. When such trouble occurs, the user may be required to take corrective actions.

## KOREA (MIC CERTIFICATION) —

**Korean Class A Warning Statement**

이 기기는 업무용으로 전자파 적합등록을 받은 기기 이오니, 판매자 또는 사용자는 이 점을 주의하시기 바라며, 만약 잘못 구입하셨을 때에는 구입한 곳에서 비업무용으로 교환하시기 바랍니다.

## KOREA CERTIFICATION — KOREA INFORMATION —

A급 기기  
 (업무용 방송통신기자재)

이 기기는 업무용(A급) 전자파적합기기로서 판매자 또는 사용자는 이 점을 주의하시기 바라며, 가정외의 지역에서 사용하는 것을 목적으로 합니다.



## Safety Standards and Compliance Agency Certifications

- CUS UL (60950-1)
- CSA 60950-1-03
- EN 60950-1
- EN 60825-1
- EN 60825-1 Safety of Laser Products—Part 1: Equipment Classification Requirements and User's Guide
- EN 60825-2 Safety of Laser Products—Part 2: Safety of Optical Fibre Communication Systems
- FDA Regulation 21CFR 1040.10 and 1040.11
- IEC 60950-1, 1st Ed, including all National Deviations and Group Differences

### Electromagnetic Compatibility (EMC)

#### Emissions

- Australia/New Zealand: AS/NZS CISPR 22:, Class A
- Canada: ICES-003, Issue-4, Class A
- Europe: EN55022 Class A
- Japan: Class A
- USA: FCC CFR47 Part 15, Subpart B, Class A

#### Immunity

- EN 300 386 EMC for Network Equipment
- EN 55024
  - EN 61000-3-2 Harmonic Current Emissions
  - EN 61000-3-3 Voltage Fluctuations and Flicker
  - EN 61000-4-2 ESD
  - EN 61000-4-3 Radiated Immunity
  - EN 61000-4-4 EFT
  - EN 61000-4-5 Surge
  - EN 61000-4-6 Low Frequency Conducted Immunity

### Product Recycling and Disposal

This switch must be recycled or discarded according to applicable local and national regulations. Dell Networking encourages owners of information technology (IT) equipment to responsibly recycle their equipment when it is no longer needed. Dell Networking offers a variety of product return programs and services in several countries to assist equipment owners in recycling their IT products.

*Waste Electrical and Electronic Equipment (WEEE) Directive for Recovery, Recycle and Reuse of IT and Telecommunications Products*

Dell Networking switches are labeled in accordance with European Directive 2002/96/EC concerning waste electrical and electronic equipment (WEEE). The Directive determines the framework for the return and recycling of used appliances as applicable throughout the European Union. This label, as shown in [Figure B-3](#), is applied to various products to indicate that the product is not to be thrown away, but rather reclaimed upon end of life per this Directive.

**Figure B-3. The European WEEE Symbol**



In accordance with the European WEEE Directive, electrical and electronic equipment (EEE) is to be collected separately and to be reused, recycled, or recovered at end of life. Users of EEE with the WEEE marking per Annex IV of the WEEE Directive, as shown above, must not dispose of end of life EEE as unsorted municipal waste, but use the collection framework available to customers for the return, recycling and recovery of WEEE. Customer participation is important to minimize any potential effects of EEE on the environment and human health due to the potential presence of hazardous substances in EEE.

Dell Networking products, which fall within the scope of the WEEE, are labeled with the crossed-out wheelie-bin symbol, as shown above, as required by WEEE.

For information on Dell Networking product recycling offerings, see the WEEE Recycling instructions on iSupport at: <https://www.force10networks.com/CSPortal20/Support/WEEEandRecycling.pdf>.

For more information, contact the Dell Networking Technical Assistance Center (TAC) (see [Contacting the Technical Assistance Center on page 55](#)).

For California:

**Perchlorate Material** — Special handling may apply.

See: <http://www.dtsc.ca.gov/hazardouswaste/perchlorate>

The foregoing notice is provided in accordance with California Code of Regulations Title 22, Division 4.5 Chapter 33. Best Management Practices for Perchlorate Materials.

# Contacting Technical Support

## The iSupport Website

iSupport provides a range of documents and tools to assist you with effectively using Dell Networking equipment and mitigating the impact of network outages. Through iSupport you can obtain technical information regarding Dell Networking products, access to software upgrades and patches, and open and manage your Technical Assistance Center (TAC) cases. Dell Networking iSupport provides integrated, secure access to these services.

### Accessing iSupport Services

The URL for iSupport is [www.force10networks.com/support/](http://www.force10networks.com/support/). To access iSupport services you must have a userid and password. If you do not have one, you can request one at the website:

- 1 On the Dell Networking iSupport page, click the **Account Request** link.
- 2 Fill out the User Account Request form and click **Send**. You will receive your userid and password by E-Mail.
- 3 To access iSupport services, click the **Log in** link and enter your userid and password.

## Contacting the Technical Assistance Center

---

How to Contact Dell Networking TAC	Log in to iSupport at <a href="http://www.force10networks.com/support/">www.force10networks.com/support/</a> , and select the <b>Service Request</b> tab.
Information to Submit When Opening a Support Case	<ul style="list-style-type: none"> <li>• Your name, company name, phone number, and E-mail address</li> <li>• Preferred method of contact</li> <li>• Model number</li> <li>• Serial Number (see <a href="#">Locating Serial Numbers on page 68</a>)</li> <li>• Software version number</li> <li>• Symptom description</li> <li>• Screen shots illustrating the symptom, including any error messages. These can include:</li> <li>• Output from the show tech command or the show tech linecard {number} command.</li> <li>• Output from the show trace command or the show trace linecard {number} command.</li> <li>• Console captures showing the error messages.</li> <li>• Console captures showing the troubleshooting steps taken.</li> <li>• Saved messages to a syslog server, if one is used.</li> </ul>
Managing Your Case	Log in to iSupport and select the <b>Service Request</b> tab to view all open cases and RMAs.
Downloading Software Updates	Log in to iSupport and select the <b>Software Center</b> tab.



Technical Documentation	Log in to iSupport, and select the <b>Documents</b> tab. This page can be accessed without logging in via the <b>Documentation</b> link on the iSupport page.
Contact Information	E-mail: <a href="mailto:support@force10networks.com">support@force10networks.com</a> Web: <a href="http://www.force10networks.com/support/">www.force10networks.com/support/</a> Telephone: US and Canada: 866.965.5800 International: 408.965.5800

## Locating Serial Numbers

- The chassis serial number is below the barcode on the sticker on the back of the chassis.
- The serial numbers for the RPM, line cards, fan tray, and power supply units are below the barcode on the sticker on the front of each component.

## Requesting a Hardware Replacement

To request replacement hardware, follow these steps:

Step	Task
1	<p>Determine the part number and serial number of the component. To list the numbers for all components installed in the chassis, use the <code>show inventory</code> command.</p> <p> <b>NOTE:</b> The serial numbers of fan trays and AC power supplies will not appear in the hardware inventory listing. Check the failed component for the attached serial number label.</p> <p> <b>NOTE:</b> Quickly reinsert the fan tray back into the chassis once you have noted the serial number.</p>
2	<p>Request a Return Materials Authorization (RMA) number from TAC by opening a support case. Open a support case by:</p> <ul style="list-style-type: none"> <li>• Using the Create Service Request form on the iSupport page (see <a href="#">Contacting the Technical Assistance Center on page 67</a>).</li> <li>• Contacting Dell Networking directly by E-mail or by phone (see <a href="#">Contacting the Technical Assistance Center on page 67</a>). Provide the following information when using E-mail or phone: <ul style="list-style-type: none"> <li>• Part number, description, and serial number of the component.</li> <li>• Your name, organization name, telephone number, fax number, and e-mail address.</li> <li>• Shipping address for the replacement component, including a contact name, phone number, and e-mail address.</li> <li>• A description of the failure, including log messages. This generally includes: <ul style="list-style-type: none"> <li>• the <code>show tech</code> command output</li> <li>• the <code>show trace</code> and <code>show trace hardware</code> command output</li> <li>• for line card issues, the <code>show trace hardware linecard</code> command output</li> <li>• console captures showing any error messages</li> <li>• console captures showing the troubleshooting steps taken</li> <li>• saved messages to a syslog server, if one is used</li> </ul> </li> </ul> </li> <li>• The support representative will validate your request and issue an RMA number for the return of the component.</li> </ul>

---

<b>Step</b>	<b>Task</b>
3	When returning an RMA component, follow the packing and shipping directions in the Return Instructions document that accompanies the replacement component. Alternatively, contact your TAC representative for a replacement copy.  Generally, you are instructed to return the RMA component in the original packaging material provided with the replacement, and to label the package with the RMA number.

---







Printed in the U.S.A.

[www.dell.com](http://www.dell.com) | [support.dell.com](http://support.dell.com)